

A  
B  
C  
D

# WT

## SECTION

### ROAD WHEELS & TIRES

WT

## CONTENTS

<p><b>PRECAUTION</b> ..... 3</p> <p><b>PRECAUTIONS</b> ..... 3</p> <p style="padding-left: 20px;">Precaution for Supplemental Restraint System (SRS) "AIR BAG" and "SEAT BELT PRE-TENSIONER" .....3</p> <p style="padding-left: 20px;">Service Notice and Precautions .....3</p> <p style="padding-left: 20px;">Precautions for Removing Battery Terminal .....3</p> <p><b>PREPARATION</b> ..... 5</p> <p><b>PREPARATION</b> ..... 5</p> <p style="padding-left: 20px;">Special Service Tool .....5</p> <p style="padding-left: 20px;">Commercial Service Tool .....5</p> <p><b>SYSTEM DESCRIPTION</b> ..... 6</p> <p><b>COMPONENT PARTS</b> ..... 6</p> <p style="padding-left: 20px;">Component Parts Location .....6</p> <p style="padding-left: 20px;">Component Description .....6</p> <p style="padding-left: 20px;">BCM .....6</p> <p style="padding-left: 20px;">Tire Pressure Sensor .....7</p> <p style="padding-left: 20px;">Tire Pressure Receiver .....7</p> <p style="padding-left: 20px;">Information Display .....7</p> <p><b>SYSTEM</b> ..... 8</p> <p style="padding-left: 20px;">System Description .....8</p> <p><b>DIAGNOSIS SYSTEM (BCM)</b> ..... 9</p> <p><b>COMMON ITEM</b> .....9</p> <p style="padding-left: 20px;">COMMON ITEM : CONSULT Function (BCM - COMMON ITEM) .....9</p> <p><b>AIR PRESSURE MONITOR</b> .....10</p> <p style="padding-left: 20px;">AIR PRESSURE MONITOR : CONSULT Function (BCM - AIR PRESSURE MONITOR) ..... 10</p> <p><b>ECU DIAGNOSIS INFORMATION</b> .....13</p> <p><b>BCM</b> .....13</p> <p style="padding-left: 20px;">List of ECU Reference ..... 13</p>	<p><b>WIRING DIAGRAM</b> .....14</p> <p><b>TIRE PRESSURE MONITORING SYSTEM</b> .....14</p> <p style="padding-left: 20px;">Wiring Diagram .....14</p> <p><b>BASIC INSPECTION</b> ..... 19</p> <p><b>DIAGNOSIS AND REPAIR WORK FLOW</b> ..... 19</p> <p style="padding-left: 20px;">Work Flow .....19</p> <p><b>ADDITIONAL SERVICE WHEN REPLACING BCM</b> .....21</p> <p style="padding-left: 20px;">Description .....21</p> <p style="padding-left: 20px;">Work Procedure .....21</p> <p><b>TIRE PRESSURE SENSOR WAKE UP OPERATION</b> .....22</p> <p style="padding-left: 20px;">Description .....22</p> <p style="padding-left: 20px;">Work Procedure .....22</p> <p><b>ID REGISTRATION</b> .....23</p> <p style="padding-left: 20px;">Description .....23</p> <p style="padding-left: 20px;">Work Procedure .....23</p> <p><b>DTC/CIRCUIT DIAGNOSIS</b> .....25</p> <p><b>C1704, C1705, C1706, C1707 LOW TIRE PRESSURE</b> .....25</p> <p style="padding-left: 20px;">Description .....25</p> <p style="padding-left: 20px;">DTC Logic .....25</p> <p style="padding-left: 20px;">Diagnosis Procedure .....25</p> <p><b>C1708, C1709, C1710, C1711 TIRE PRESSURE SENSOR</b> .....27</p> <p style="padding-left: 20px;">DTC Logic .....27</p> <p style="padding-left: 20px;">Diagnosis Procedure .....27</p> <p><b>C1716, C1717, C1718, C1719 TIRE PRESSURE SENSOR</b> .....30</p> <p style="padding-left: 20px;">DTC Logic .....30</p> <p style="padding-left: 20px;">Diagnosis Procedure .....30</p>	<p>F G H I J K L M N O P</p>
--	---	--

<b>C1729 VEHICLE SPEED SIGNAL</b> .....	<b>31</b>	Diagnosis Procedure .....	42
Description .....	31		
DTC Logic .....	31		
Diagnosis Procedure .....	31		
<b>C1734 BCM</b> .....	<b>32</b>		
DTC Logic .....	32		
Diagnosis Procedure .....	32		
<b>TIRE PRESSURE RECEIVER</b> .....	<b>34</b>		
Component Function Check .....	34		
Diagnosis Procedure .....	34		
<b>LOW TIRE PRESSURE WARNING LAMP</b> .....	<b>36</b>		
Component Function Check .....	36		
Diagnosis Procedure .....	36		
<b>POWER SUPPLY AND GROUND CIRCUIT</b> ....	<b>37</b>		
Diagnosis Procedure .....	37		
<b>SYMPTOM DIAGNOSIS</b> .....	<b>38</b>		
<b>TPMS</b> .....	<b>38</b>		
Symptom Table .....	38		
<b>LOW TIRE PRESSURE WARNING LAMP</b>			
<b>DOES NOT TURN ON</b> .....	<b>40</b>		
Description .....	40		
Diagnosis Procedure .....	40		
<b>LOW TIRE PRESSURE WARNING LAMP</b>			
<b>DOES NOT TURN OFF</b> .....	<b>41</b>		
Description .....	41		
Diagnosis Procedure .....	41		
<b>LOW TIRE PRESSURE WARNING LAMP</b>			
<b>BLINKS</b> .....	<b>42</b>		
Description .....	42		
		<b>ID REGISTRATION CANNOT BE COMPLET-</b>	
		<b>ED</b> .....	<b>43</b>
		Description .....	43
		Diagnosis Procedure .....	43
		<b>NOISE, VIBRATION AND HARSHNESS</b>	
		<b>(NVH) TROUBLESHOOTING</b> .....	<b>44</b>
		NVH Troubleshooting Chart .....	44
		<b>PERIODIC MAINTENANCE</b> .....	<b>45</b>
		<b>ROAD WHEEL</b> .....	<b>45</b>
		Adjustment .....	45
		<b>REMOVAL AND INSTALLATION</b> .....	<b>47</b>
		<b>ROAD WHEEL TIRE ASSEMBLY</b> .....	<b>47</b>
		Exploded View .....	47
		Removal and Installation .....	47
		Inspection .....	47
		<b>TIRE PRESSURE SENSOR</b> .....	<b>49</b>
		Exploded View .....	49
		Removal and Installation .....	49
		<b>TIRE PRESSURE RECEIVER</b> .....	<b>51</b>
		Exploded View .....	51
		Removal and Installation .....	51
		<b>SERVICE DATA AND SPECIFICATIONS</b>	
		<b>(SDS)</b> .....	<b>52</b>
		<b>SERVICE DATA AND SPECIFICATIONS</b>	
		<b>(SDS)</b> .....	<b>52</b>
		Road Wheel .....	52
		Tire Air Pressure .....	52

# PRECAUTIONS

< PRECAUTION >

## PRECAUTION

### PRECAUTIONS

#### Precaution for Supplemental Restraint System (SRS) "AIR BAG" and "SEAT BELT PRE-TENSIONER"

INFOID:000000010993945

The Supplemental Restraint System such as "AIR BAG" and "SEAT BELT PRE-TENSIONER", used along with a front seat belt, helps to reduce the risk or severity of injury to the driver and front passenger for certain types of collision. This system includes seat belt switch inputs and dual stage front air bag modules. The SRS system uses the seat belt switches to determine the front air bag deployment, and may only deploy one front air bag, depending on the severity of a collision and whether the front occupants are belted or unbelted. Information necessary to service the system safely is included in the "SRS AIR BAG" and "SEAT BELT" of this Service Manual.

#### **WARNING:**

Always observe the following items for preventing accidental activation.

- To avoid rendering the SRS inoperative, which could increase the risk of personal injury or death in the event of a collision that would result in air bag inflation, all maintenance must be performed by an authorized NISSAN/INFINITI dealer.
- Improper maintenance, including incorrect removal and installation of the SRS, can lead to personal injury caused by unintentional activation of the system. For removal of Spiral Cable and Air Bag Module, see "SRS AIR BAG".
- Never use electrical test equipment on any circuit related to the SRS unless instructed to in this Service Manual. SRS wiring harnesses can be identified by yellow and/or orange harnesses or harness connectors.

#### PRECAUTIONS WHEN USING POWER TOOLS (AIR OR ELECTRIC) AND HAMMERS

#### **WARNING:**

Always observe the following items for preventing accidental activation.

- When working near the Air Bag Diagnosis Sensor Unit or other Air Bag System sensors with the ignition ON or engine running, never use air or electric power tools or strike near the sensor(s) with a hammer. Heavy vibration could activate the sensor(s) and deploy the air bag(s), possibly causing serious injury.
- When using air or electric power tools or hammers, always switch the ignition OFF, disconnect the battery, and wait at least 3 minutes before performing any service.

#### Service Notice and Precautions

INFOID:000000010993946

- Low tire pressure warning lamp blinks for 1min, then turns ON when occurring any malfunction except low tire pressure. Delete the memory with CONSULT, or register the ID to turn low tire pressure warning lamp OFF. Refer to [WT-10. "AIR PRESSURE MONITOR : CONSULT Function \(BCM - AIR PRESSURE MONITOR\)"](#), [WT-23. "Work Procedure"](#).
- ID registration is required when replacing or rotating wheels, replacing tire pressure sensor or BCM. Refer to [BCS-90. "Exploded View"](#).
- Replace grommet seal, valve core and cap of tire pressure sensor in TPMS every tire replacement by reaching wear limit of tire. Refer to [WT-49. "Exploded View"](#).

#### Precautions for Removing Battery Terminal

INFOID:000000011337880

- When removing the 12V battery terminal, turn OFF the ignition switch and wait at least 30 seconds.

#### **NOTE:**

ECU may be active for several tens of seconds after the ignition switch is turned OFF. If the battery terminal is removed before ECU stops, then a DTC detection error or ECU data corruption may occur.

- For vehicles with the 2-batteries, be sure to connect the main battery and the sub battery before turning ON the ignition switch.

#### **NOTE:**

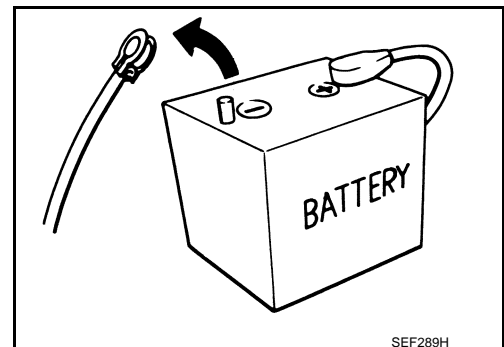

SEF289H

## PRECAUTIONS

### < PRECAUTION >

---

If the ignition switch is turned ON with any one of the terminals of main battery and sub battery disconnected, then DTC may be detected.

- After installing the 12V battery, always check "Self Diagnosis Result" of all ECUs and erase DTC.

**NOTE:**

The removal of 12V battery may cause a DTC detection error.

# PREPARATION

< PREPARATION >



## PREPARATION

### PREPARATION

#### Special Service Tool

INFOID:0000000010993947

The actual shapes of TechMate tools may differ from those of special service tools illustrated here.

Tool number (TechMate No.) Tool name	Description
<p>— (J-50190) Signal tech II</p>  <p>ALEIA0131ZZ</p>	<ul style="list-style-type: none"> <li>• Activate and display TPMS tire pressure sensor IDs</li> <li>• Display tire pressure reported by the TPMS tire pressure sensor</li> <li>• Read TPMS DTCs</li> <li>• Register TPMS tire pressure sensor IDs</li> <li>• Test remote keyless entry keyfob relative signal strength</li> <li>• Compatible with future sensors</li> <li>• Equipped with a display</li> </ul>
<p>KV48105501 (J-45295-A) Tire pressure sensor activation tool</p>  <p>ALEIA0183ZZ</p>	<ul style="list-style-type: none"> <li>• Activate TPMS tire pressure sensor IDs</li> <li>• Compatible with future sensors</li> <li>• Equipped with a display (KV48105501 only)</li> </ul>

#### Commercial Service Tool

INFOID:0000000010993948

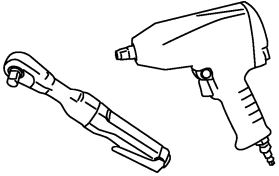
Tool name	Description
<p>Power tool</p>  <p>PBIC0190E</p>	<p>Loosening wheel nuts</p>

# COMPONENT PARTS

< SYSTEM DESCRIPTION >

## SYSTEM DESCRIPTION

### COMPONENT PARTS

#### Component Parts Location

INFOID:0000000010993949

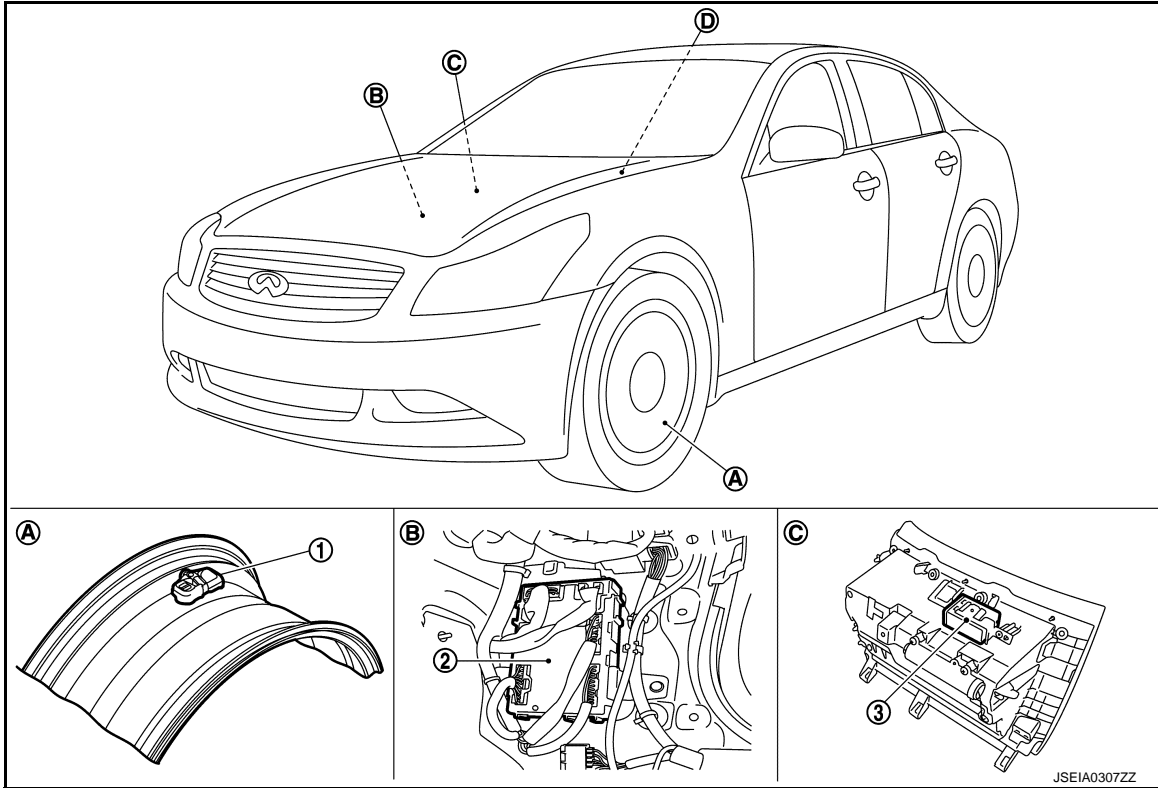

- |   |                                     |                              |
|---|-------------------------------------|------------------------------|
| 1. Tire pressure sensor   | 2. BCM                              | 3. Tire pressure receiver    |
| A. Wheel  | B. Dash side lower (passenger side) | C. Instrument lower panel RH |
| D. Low tire pressure warning lamp, information display (in combination meter) |                                     |                              |

#### Component Description

INFOID:0000000010993950

Component parts	Function
BCM (Body Control Module)	<a href="#">WT-6. "BCM"</a> .
Tire pressure sensor	<a href="#">WT-7. "Tire Pressure Sensor"</a> .
Tire pressure receiver	<a href="#">WT-7. "Tire Pressure Receiver"</a> .
Turn signal lamp	ID registration of each wheel has been completed, turn signal lamp flashes.
Unified meter and A/C amp.	Transmits the vehicle speed signal via CAN communication to BCM.
	Receives the following signals via CAN communication for BCM. <ul style="list-style-type: none"> <li>• Low tire pressure warning lamp signal</li> <li>• TPMS malfunction warning lamp signal</li> </ul>
Low tire pressure warning lamp	<a href="#">WT-8. "System Description"</a>
Information display	<a href="#">WT-7. "Information Display"</a>

#### BCM

INFOID:0000000010993951

The BCM reads the air pressure signal received by the tire pressure receiver, and controls the low tire pressure warning lamp operation. It also has a judgment function to detect a system malfunction.

# COMPONENT PARTS

## < SYSTEM DESCRIPTION >

### Tire Pressure Sensor

INFOID:000000010993952

The tire pressure sensor integrated with a valve is installed on a wheel, and transmits a detected air pressure signal by radio wave.

### Tire Pressure Receiver

INFOID:000000010993953

The tire pressure receiver receives the air pressure signal transmitted by the tire pressure sensor in each wheel.

### Information Display

INFOID:000000010993954

The vehicle information display is shown when a low tire pressure warning lamp signal is transmitted from BCM to Unified meter and A/C amp. via CAN communication.

Condition	Vehicle information display
Ignition switch OFF	Non-indication
Low tire pressure	Indication

A  
B  
C  
D  
F  
G  
H  
I  
J  
K  
L  
M  
N  
O  
P

WT

# SYSTEM

< SYSTEM DESCRIPTION >

## SYSTEM

### System Description

INFOID:000000010993955

During driving, the TPMS (Tire Pressure Monitoring System) receives the signal transmitted from tire pressure sensor installed in each wheel. The BCM (Body Control Module) of this system has pressure judgment and trouble diagnosis functions. When the tire pressure monitoring system detects low inflation pressure or another unusual symptom, the low tire pressure warning lamps in the unified meter and A/C amp. comes on.

### SYSTEM DIAGRAM

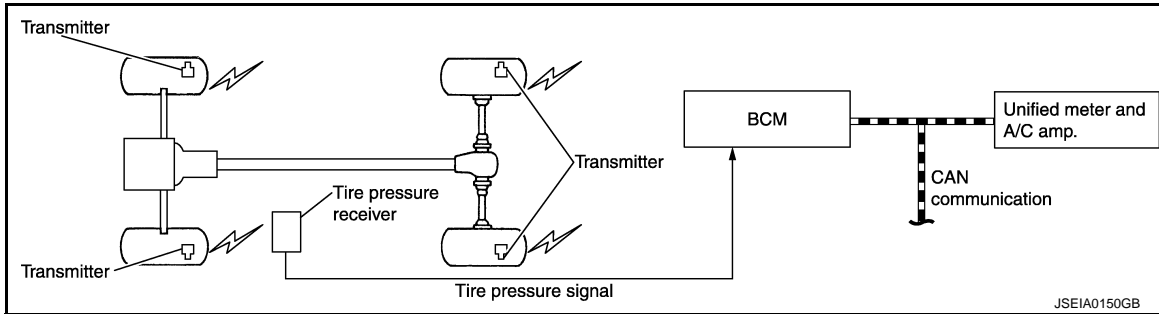

### INPUT/OUTPUT SIGNAL

The signal transmission/reception between units via a communication line is mainly as listed in the following table.

Component parts	Signal item
BCM	Transmits the following signals via CAN communication to unified meter and A/C amp. <ul style="list-style-type: none"> <li>• Low tire pressure warning lamp signal</li> <li>• TPMS malfunction warning lamp signal</li> </ul>
Unified meter and A/C amp.	Transmits the vehicle speed signal via CAN communication to BCM.

### LOW TIRE PRESSURE WARNING LAMP INDICATION CONDITION

Uses CAN communication from the BCM to illuminate the low tire pressure warning lamp on the unified meter and A/C amp.

Condition	Low tire pressure warning lamp
Ignition switch OFF	OFF
Ignition switch ON (system normal)	Warning lamp turns on for 1second, then turns off.
Low tire pressure	ON
Tire pressure sensor ID not registered in BCM.	
Tire pressure monitoring system malfunction (Other diagnostic item)	Warning lamp blinks 1 min, then turns on.
Tire pressure sensor is in OFF state	Blink (Blinking pattern depends on the positions of non-operational tire pressure sensors.)



# DIAGNOSIS SYSTEM (BCM)

< SYSTEM DESCRIPTION >

## DIAGNOSIS SYSTEM (BCM)

### COMMON ITEM

#### COMMON ITEM : CONSULT Function (BCM - COMMON ITEM)

INFOID:0000000010993956

#### APPLICATION ITEM

CONSULT performs the following functions via CAN communication with BCM.

Diagnosis mode	Function Description
Work Support	Changes the setting for each system function.
Self Diagnostic Result	Displays the diagnosis results judged by BCM.
CAN Diag Support Monitor	Monitors the reception status of CAN communication viewed from BCM.
Data Monitor	The BCM input/output signals are displayed.
Active Test	The signals used to activate each device are forcibly supplied from BCM.
Ecu Identification	The BCM part number is displayed.
Configuration	This function is not used even though it is displayed.

#### SYSTEM APPLICATION

BCM can perform the following functions for each system.

#### NOTE:

It can perform the diagnosis modes except the following for all sub system selection items.

x: Applicable item

System	Sub system selection item	Diagnosis mode		
		Work Support	Data Monitor	Active Test
Door lock	DOOR LOCK	x	x	x
Rear window defogger	REAR DEFOGGER		x	x
Warning chime	BUZZER		x	x
Interior room lamp timer	INT LAMP	x	x	x
Exterior lamp	HEAD LAMP	x	x	x
Wiper and washer	WIPER	x	x	x
Turn signal and hazard warning lamps	FLASHER	x	x	x
—	AIR CONDITONER*			
• Intelligent Key system • Engine start system	INTELLIGENT KEY	x	x	x
Combination switch	COMB SW		x	
Body control system	BCM	x		
IVIS - NATS	IMMU		x	x
Interior room lamp battery saver	BATTERY SAVER	x	x	x
Trunk lid open	TRUNK		x	x
Vehicle security system	THEFT ALM	x	x	x
RAP system	RETAINED PWR		x	
Signal buffer system	SIGNAL BUFFER		x	x
TPMS	AIR PRESSURE MONITOR	x	x	x

#### NOTE:

\*: This item is displayed, but is not used.

#### FREEZE FRAME DATA (FFD)

The BCM records the following vehicle condition at the time a particular DTC is detected, and displays on CONSULT.

# DIAGNOSIS SYSTEM (BCM)

## < SYSTEM DESCRIPTION >

CONSULT screen item	Indication/Unit	Description	
Vehicle Speed	km/h	Vehicle speed of the moment a particular DTC is detected	
Odo/Trip Meter	km	Total mileage (Odometer value) of the moment a particular DTC is detected	
Vehicle Condition	SLEEP>LOCK	Power position status of the moment a particular DTC is detected	While turning BCM status from low power consumption mode to normal mode (Power supply position is "LOCK"*)
	SLEEP>OFF		While turning BCM status from low power consumption mode to normal mode (Power supply position is "OFF".)
	LOCK>ACC		While turning power supply position from "LOCK"* to "ACC"
	ACC>ON		While turning power supply position from "ACC" to "IGN"
	RUN>ACC		While turning power supply position from "RUN" to "ACC" (Vehicle is stopping and selector lever is except P position.)
	CRANK>RUN		While turning power supply position from "CRANKING" to "RUN" (From cranking up the engine to run it)
	RUN>URGENT		While turning power supply position from "RUN" to "ACC" (Emergency stop operation)
	ACC>OFF		While turning power supply position from "ACC" to "OFF"
	OFF>LOCK		While turning power supply position from "OFF" to "LOCK"*
	OFF>ACC		While turning power supply position from "OFF" to "ACC"
	ON>CRANK		While turning power supply position from "IGN" to "CRANKING"
	OFF>SLEEP		While turning BCM status from normal mode (Power supply position is "OFF".) to low power consumption mode
	LOCK>SLEEP		While turning BCM status from normal mode (Power supply position is "LOCK"*. ) to low power consumption mode
	LOCK		Power supply position is "LOCK"*
	OFF		Power supply position is "OFF" (Ignition switch OFF)
	ACC		Power supply position is "ACC" (Ignition switch ACC)
	ON		Power supply position is "IGN" (Ignition switch ON with engine stopped)
	ENGINE RUN		Power supply position is "RUN" (Ignition switch ON with engine running)
	CRANKING		Power supply position is "CRANKING" (At engine cranking)
IGN Counter	0 - 39	The number of times that ignition switch is turned ON after DTC is detected <ul style="list-style-type: none"> <li>• The number is 0 when a malfunction is detected now.</li> <li>• The number increases like 1 → 2 → 3...38 → 39 after returning to the normal condition whenever ignition switch OFF → ON.</li> <li>• The number is fixed to 39 until the self-diagnosis results are erased if it is over 39.</li> </ul>	

### NOTE:

\*: Power supply position shifts to "LOCK" from "OFF", when ignition switch is in the OFF position, selector lever is in the P position (A/T models), and any of the following conditions are met.

- Closing door
- Opening door
- Door is locked using door request switch
- Door is locked using Intelligent Key

The power supply position shifts to "ACC" when the push-button ignition switch (push switch) is pushed at "LOCK".

## AIR PRESSURE MONITOR

### AIR PRESSURE MONITOR : CONSULT Function (BCM - AIR PRESSURE MONITOR)

INFOID:000000010993957

### APPLICATION ITEM

CONSULT performs the following functions via CAN communication with BCM.

# DIAGNOSIS SYSTEM (BCM)

## < SYSTEM DESCRIPTION >

Diagnosis mode	Function Description
Self Diagnostic Result	Displays the diagnosis results judged by BCM.
Data Monitor	The BCM input/output signals are displayed.
Active Test	The signals used to activate each device are forcibly supplied from BCM.
Work Support	Components can be quickly and accurately adjusted.

### SELF DIAGNOSTIC RESULT

Refer to [BCS-84, "DTC Index"](#).

When "CRNT" is displayed on self-diagnosis result,

- The system is presently malfunctioning.

When "PAST" is displayed on self-diagnosis result,

- System malfunction in the past is detected, but the system is presently normal.

### DATA MONITOR MODE

Screen of data monitor mode is displayed.

#### NOTE:

- When malfunction is detected, CONSULT perform REAL-TIME DIAGNOSIS. Also, any malfunction detected while in this mode will be displayed at real time.
- The following table includes information (items) inapplicable to this vehicle. For information (items) applicable to this vehicle, refer to CONSULT display items.

Monitor item (Unit)	Remark
AIR PRESS FL (kPa/kg/cm <sup>2</sup> /Psi)	Tire pressure
AIR PRESS FR (kPa/kg/cm <sup>2</sup> /Psi)	
AIR PRESS RR (kPa/kg/cm <sup>2</sup> /Psi)	
AIR PRESS RL (kPa/kg/cm <sup>2</sup> /Psi)	
ID REGST FL1 (Green/Red)	Registration ID
ID REGST FR1 (Green/Red)	
ID REGST RR1 (Green/Red)	
ID REGST RL1 (Green/Red)	
WARNING LAMP (On/Off)	Low tire pressure warning lamp
BUZZER (On/Off)	<b>NOTE:</b> This item is displayed, but cannot be use this item.

#### NOTE:

Before performing the self-diagnosis, be sure to register the ID, or erase the actual malfunction location may be different from that displayed on CONSULT.

### ACTIVE TEST MODE

#### NOTE:

Before performing the self-diagnosis, be sure to register the ID, or erase the actual malfunction may be different from that displayed on CONSULT.

### TEST ITEM LIST

Test item	Content
WARNING LAMP	This test is able to check to check that the low tire pressure warning lamp turns on.
ID REGIST WARNING	This test is able to check to check that the low tire pressure warning lamp turns on.
FLASHER	This test is able to check to check that each turn signal lamp turns on.
HORN	This test is able to check to check that the horn sounds.

### WORK SUPPORT MODE

## DIAGNOSIS SYSTEM (BCM)

### < SYSTEM DESCRIPTION >

Item	Description
ID READ	Registered tire pressure sensor ID can be displayed.
ID REGIST	Tire pressure sensor ID can be registered.

# BCM

< ECU DIAGNOSIS INFORMATION >

## ECU DIAGNOSIS INFORMATION

BCM

List of ECU Reference

INFOID:0000000010993958

ECU	Reference
	<a href="#">BCS-45, "Reference Value"</a>
BCM	<a href="#">BCS-82, "Fail-safe"</a>
	<a href="#">BCS-83, "DTC Inspection Priority Chart"</a>
	<a href="#">BCS-84, "DTC Index"</a>

A

B

C

D

WT

F

G

H

I

J

K

L

M

N

O

P

# TIRE PRESSURE MONITORING SYSTEM

< WIRING DIAGRAM >

## WIRING DIAGRAM

### TIRE PRESSURE MONITORING SYSTEM

Wiring Diagram

INFOID:0000000010993959

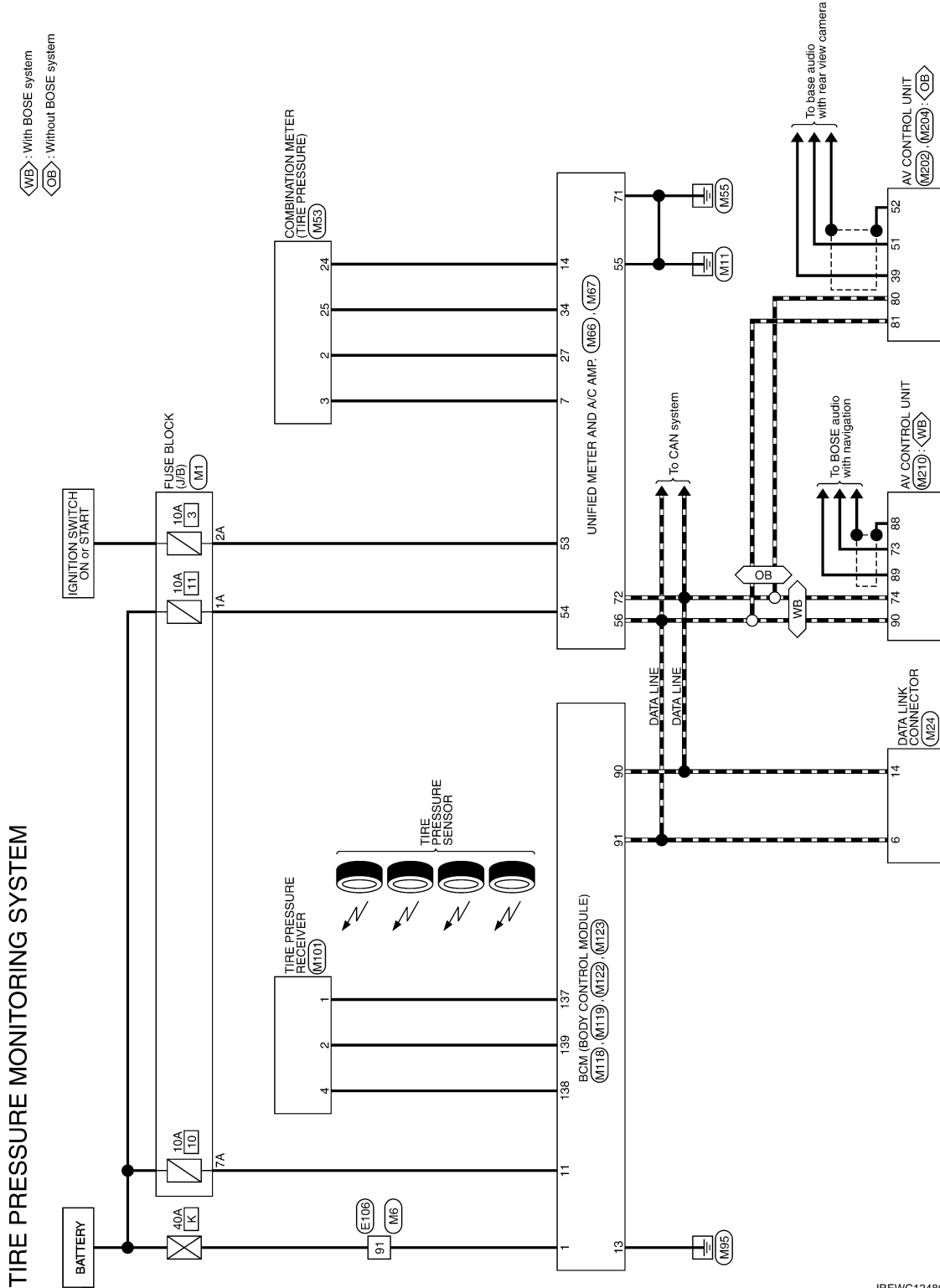

2014/06/09

JREW1248GB

# TIRE PRESSURE MONITORING SYSTEM

< WIRING DIAGRAM >

## TIRE PRESSURE MONITORING SYSTEM

Connector No.	E106
Connector Name	WIRE TO WIRE
Connector Type	TH80FW-C51P-TM4



Terminal No.	Color Of Wire	Signal Name [Specification]
1	GR	
2	BG	
3	G	
4	V	
5	R	
6	Y	
7	W	
8	LG	
9	GR	
10	SB	
11	V	
12	R	
13	L	
14	GR	
15	P	
16	W	
17	SB	
18	BG	
19	LG	
20	G	
21	BG	
22	P	
23	SB	
24	Y	
25	R	
26	B	
27	L	
28	R	
29	B	
30	R	
31	R	
32	R	
33	R	
34	R	
35	R	
36	R	
37	Y	
38	R	
39	B	
40	R	
41	R	
42	LG	
43	G	
44	GR	
45	BR	
46	LG	
47	V	
48	P	
49	SB	
50	LG	
51	R	
52	P	
53	G	

Connector No.	M6
Connector Name	WIRE TO WIRE
Connector Type	TH80FW-C51P-TM4

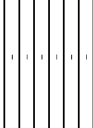

Terminal No.	Color Of Wire	Signal Name [Specification]
1	BG	
2	R	
3	G	
4	LG	
5	W	
6	G	
7	W	
8	G	
9	V	
10	V	
11	V	
12	R	
13	L	
14	GR	
15	P	
16	W	
17	BR	
18	P	
19	L	
20	G	
21	Y	
22	Y	
23	L	
24	R	
25	Y	
26	R	
27	Y	
28	R	
29	SB	
30	SB	
31	V	
32	V	
33	V	
34	V	
35	V	
36	V	
37	V	
38	R	
39	SB	
40	V	
41	V	
42	LG	
43	P	
44	B	
45	BG	
46	G	
47	L	
48	P	
49	Y	
50	Y	
51	G	
52	SB	
53	B	
54	V	

Connector No.	M1
Connector Name	FUSE BLOCK (J/B)
Connector Type	NSB5FW-M2

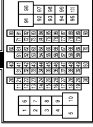

Terminal No.	Color Of Wire	Signal Name [Specification]
1	BG	
2	R	
3	G	
4	LG	
5	W	
6	G	
7	W	
8	G	
9	V	
10	V	
11	V	
12	R	
13	L	
14	GR	
15	P	
16	W	
17	BR	
18	P	
19	L	
20	G	
21	Y	
22	Y	
23	L	
24	R	
25	Y	
26	R	
27	Y	
28	R	
29	SB	
30	SB	
31	V	
32	V	
33	V	
34	V	
35	V	
36	V	
37	V	
38	R	
39	SB	
40	V	
41	V	
42	LG	
43	P	
44	B	
45	BG	
46	G	
47	L	
48	P	
49	Y	
50	Y	
51	G	
52	SB	
53	B	
54	V	

Connector No.	M24
Connector Name	DATA LINK CONNECTOR
Connector Type	BD1EFP-P

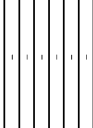

Terminal No.	Color Of Wire	Signal Name [Specification]
1	BG	
2	R	
3	G	
4	LG	
5	W	
6	G	
7	W	
8	G	
9	V	
10	V	
11	V	
12	R	
13	L	
14	GR	
15	P	
16	W	
17	BR	
18	P	
19	L	
20	G	
21	Y	
22	Y	
23	L	
24	R	
25	Y	
26	R	
27	Y	
28	R	
29	SB	
30	SB	
31	V	
32	V	
33	V	
34	V	
35	V	
36	V	
37	V	
38	R	
39	SB	
40	V	
41	V	
42	LG	
43	P	
44	B	
45	BG	
46	G	
47	L	
48	P	
49	Y	
50	Y	
51	G	
52	SB	
53	B	
54	V	

A  
B  
C  
D  
WT  
F  
G  
H  
I  
J  
K  
L  
M  
N  
O  
P

# TIRE PRESSURE MONITORING SYSTEM

< WIRING DIAGRAM >

## TIRE PRESSURE MONITORING SYSTEM

Connector No.	M13
Connector Name	COMBINATION METER
Connector Type	SAB40FW

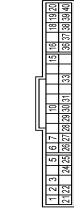

Connector No.	M66
Connector Name	UNFIED METER AND A/C AMP.
Connector Type	TH427W-NH



Terminal No.	Color Of Wire	Signal Name [Specification]
1	LG	BATTERY POWER SUPPLY
2	LG	COMMUNICATION SIGNAL (METER-AMP)
3	GR	COMMUNICATION SIGNAL (AMP-METER)
4	GR	COMMUNICATION SIGNAL (AMP-METER)
5	B	GROUND
6	W	ALTERNATOR SIGNAL
7	LG	AIR BAG SIGNAL
10	W	SECURITY SIGNAL
11	W	GROUND
15	B	METER CONTROL SWITCH GROUND
16	GR	ILL GND
19	B	ILL
20	R	ILL
21	G	IGNITION SIGNAL
22	B	GROUND
24	BR	COMMUNICATION SIGNAL (LGD-AMP)
25	BR	COMMUNICATION SIGNAL (AMP-LGD)
26	R	VEHICLE SPEED SIGNAL (2-PULSE)
27	P	PARKING BRAKE SWITCH SIGNAL
28	SB	BRAKE FLUID LEVEL SWITCH
29	P	SEAT BELT BUCKLE SW SIGNAL (DRIVER SIDE)
30	G	SEAT BELT BUCKLE SW SIGNAL (PASSENGER SIDE)
31	L	WASHER LEVEL CONTROL SIGNAL
33	R	ILLUMINATION CONTROL SIGNAL
36	LG	SELECT SWITCH SIGNAL
37	Y	ENTER SWITCH SIGNAL
38	G	TRIP A/B RESET SWITCH SIGNAL
39	P	ILLUMINATION CONTROL SWITCH SIGNAL (-)
40	BG	ILLUMINATION CONTROL SWITCH SIGNAL (+)



Terminal No.	Color Of Wire	Signal Name [Specification]
46	Y	SUNLOAD SENSOR SIGNAL
53	W	SUNLOAD SENSOR SUPPLY
54	SB	BATTERY POWER SUPPLY
55	B	GROUND
56	L	CAN-H
57	LG	BRAKE FLUID LEVEL SWITCH
58	Y	FUEL LEVEL SENSOR GROUND
59	GR	INTAKE SENSOR GROUND
60	W	IN-VEHICLE SENSOR GROUND
61	B	AMBIENT SENSOR GROUND
62	SB	SUNLOAD SENSOR GROUND
65	BG	ECV SIGNAL
69	P	A/C LAN SIGNAL
70	R	EACH DOOR MOTOR POWER SUPPLY
71	GR	GROUND
72	P	CAN-L

Connector No.	M101
Connector Name	TIRE PRESSURE RECEIVER
Connector Type	TK06FW



Terminal No.	Color Of Wire	Signal Name [Specification]
1	P	GROUND
2	L	SIGNAL
4	V	BATTERY



Connector No.	M118
Connector Name	BCM (BODY CONTROL MODULE)
Connector Type	M03FB-1C



Terminal No.	Color Of Wire	Signal Name [Specification]
1	Y	BAT (+)
2	Y	POWER WINDOW POWER SUPPLY (BAT)
3	BG	POWER WINDOW POWER SUPPLY (BAT)

Connector No.	M119
Connector Name	BCM (BODY CONTROL MODULE)
Connector Type	NS16FW-CS

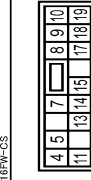

Terminal No.	Color Of Wire	Signal Name [Specification]
4	LG	INTERIOR ROOM LAMP POWER SUPPLY
5	P	PASSENGER DOOR UNLOCK OUTPUT
7	SB	STEP LAMP CONT
8	V	ALL DOOR FUEL LID LOCK OUTPUT
9	G	DRIVER DOOR FUEL LID UNLOCK OUTPUT
10	P	REAR DOOR UNLOCK OUTPUT
11	R	BAT/FUSE
13	B	GROUND
14	W	PUSH BUTTON IGNITION SW ILL GND
15	BG	TURN SIGNAL (FRONT)
18	BG	TURN SIGNAL (LH FRONT)
18	V	RHT ROOM LAMP CONT

JREW1250GB



# TIRE PRESSURE MONITORING SYSTEM

< WIRING DIAGRAM >

## TIRE PRESSURE MONITORING SYSTEM

Connector No.	M122
Connector Name	BCM (BODY CONTROL MODULE)
Connector Type	TH40FB-NH

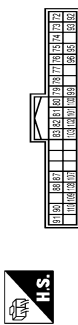

Connector No.	M123
Connector Name	BCM (BODY CONTROL MODULE)
Connector Type	TH40FC-NH

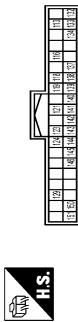

Connector No.	M202
Connector Name	AV CONTROL UNIT
Connector Type	TH32FW-NH

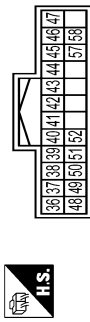

Terminal No.	Color	Wire	Signal Name [Specification]
72	R	EG	ROOM ANT 2-
73	R	EG	ROOM ANT 1-
74	BR	SB	PASSENGER DOOR ANT-
75	BR	SB	PASSENGER DOOR ANT+
76	V	LG	DRIVER DOOR ANT-
77	V	LG	DRIVER DOOR ANT+
78	Y	BR	ROOM ANT 1+
79	BR	SB	ROOM ANT 1-
80	GR	W	NATS ANT AMP
81	W	Y	IGN RELAY (F/B) CONT
82	SB	Y	KEYLESS ENTRY RECEIVER COMM
83	Y	BR	COMBI SW INPUT 5
84	EG	V	COMBI SW INPUT 3
85	GR	LG	CAN-L
86	GR	LG	CON IND
87	GR	LG	KEY SLOT 1 CONT
88	GR	LG	ACC RELAY CONT
89	R	R	SHIFT P
90	Y	Y	PASSENGER DOOR REQUEST SW
91	P	P	DRIVER DOOR REQUEST SW
92	EG	EG	BLOWER FAN MOTOR RELAY CONT
93	P	P	KEYLESS ENTRY RECEIVER POWER SUPPLY
94	R	R	COMBI SW INPUT 1
95	W	W	COMBI SW INPUT 4
96	W	W	COMBI SW INPUT 2
97	G	G	HAZARD SW

Terminal No.	Color	Wire	Signal Name [Specification]
113	EG	EG	OPTICAL SENSOR
114	EG	EG	STOP LAMP SW
115	BR	SB	STOP LAMP 2
116	BR	SB	DR DOOR UNLOCK SENSOR
117	SS	SS	KEY SLOT SW
118	V	V	IGN F/B
119	R	R	PASSENGER DOOR SW
120	EG	EG	TRUNK LID OPERATOR CANCEL SW
121	V	V	POWER WINDOW SW COMM
122	V	V	PUSH-BUTTON IGNITION SW ILL POWER
123	L	L	LOCK IND
124	LG	LG	RECEIVER / SENSOR GND
125	EG	EG	RECEIVER / SENSOR POWER SUPPLY
126	V	V	SHIFT IN P
127	L	L	TIRE PRESSURE RECEIVER COMM
128	B	B	SECURE SW INPUT CONT
129	BR	SB	COMBI SW OUTPUT 3
130	BR	SB	COMBI SW OUTPUT 1
131	BR	SB	COMBI SW OUTPUT 2
132	G	G	COMBI SW OUTPUT 4
133	L	L	COMBI SW OUTPUT 5
134	LG	LG	DRIVER DOOR SW
135	GR	W	REAR WINDOW DEFROGGER RELAY CONT

Terminal No.	Color	Wire	Signal Name [Specification]
36	EG	EG	SIGNAL VCC
37	EG	EG	SIGNAL GND
38	R	R	COMB DISP-CONT
39	L	L	COMB DISP-SIGNAL
40	B	B	RGB AREA VCS SIGNAL
41	SHIELD	SHIELD	SHIELD
42	W	W	RGB SYNC
43	G	G	RGB (R/RED) SIGNAL
44	L	L	RGB (G/GREEN) SIGNAL
45	P	P	RGB (B/BLUE) SIGNAL
46	Y	Y	COMPOSITE IMAGE GND
47	BR	SB	COMPOSITE IMAGE SIGNAL
48	Y	Y	INVERTER VCC
49	BR	SB	INVERTER GND
50	G	G	COMB DISP-CONT
51	V	V	COMB DISP-SIGNAL
52	SHIELD	SHIELD	SHIELD
53	SHIELD	SHIELD	SHIELD
54	SHIELD	SHIELD	SHIELD
55	SHIELD	SHIELD	SHIELD

Connector No.	M204
Connector Name	AV CONTROL UNIT
Connector Type	TH32FW-NH

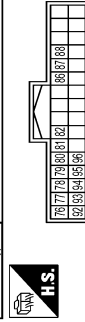

Terminal No.	Color	Wire	Signal Name [Specification]
65	SB	SB	PARKING BRAKE
66	P	P	COMPOSITE IMAGE GND
67	L	L	COMPOSITE IMAGE SIGNAL
68	L	L	MICROPHONE GND
69	G	G	MICROPHONE VCC
70	P	P	COMM (CONT-DISP)
71	P	P	CAN-L
72	LG	LG	AV COMM (L)
73	LG	LG	AV COMM (R)
74	LG	LG	ILLUMINATION
75	EG	EG	REVERSE
76	R	R	VEHICLE SPEED (8-PULSE)
77	SHIELD	SHIELD	SHIELD
78	R	R	MICROPHONE SIGNAL
79	SHIELD	SHIELD	SHIELD
80	L	L	COMM (DISP-CONT)

Connector No.	M210
Connector Name	AV CONTROL UNIT
Connector Type	TH32FW-NH

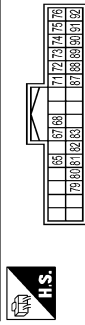

JREW1251GB

A B C D E F G H I J K L M N O P

WT

# TIRE PRESSURE MONITORING SYSTEM

< WIRING DIAGRAM >

---

TIRE PRESSURE MONITORING SYSTEM	
89	AV CSMT (4)
90	AV CSMT (5)
91	AV CSMT (4)
92	AV CSMT (5)

JREW1252GB

# DIAGNOSIS AND REPAIR WORK FLOW

< BASIC INSPECTION >

## BASIC INSPECTION

### DIAGNOSIS AND REPAIR WORK FLOW

Work Flow

INFOID:0000000010993960

DETAILED FLOW

#### 1. COLLECT THE INFORMATION FROM THE CUSTOMER

It is also important to clarify customer concerns before starting the inspection. Reproduce the symptom, and understand it fully. Interview the customer about the concerns carefully. In some cases, it is necessary to check the symptoms by driving the vehicle with the customer.

**CAUTION:**

**Customers are not professionals. Never assume “maybe the customer means...” or “maybe the customer mentioned this symptom.”**

>> GO TO 2.

#### 2. BASIC INSPECTION

1. Turn the ignition switch ON.

**CAUTION:**

**Never start the engine.**

2. Check the tire pressure for all wheels and adjust to the specified value. Refer to [WT-52, "Tire Air Pressure"](#).

Is the inspection result normal?

YES >> GO TO 3.

NO >> Inspect or repair the tires or wheels.

#### 3. CHECK LOW TIRE PRESSURE WARNING LAMP

Check low tire pressure warning lamp display.

Does not low tire pressure warning lamp turn OFF?

YES >> GO TO 4.

NO >> INSPECTION END

#### 4. CRUISE TEST

Start the engine and drive the vehicle.

>> GO TO 5.

#### 5. PERFORM SELF-DIAGNOSIS

 **With CONSULT**

Perform "SELF-DIAG RESULTS".

Is any DTC detected?

YES >> Record or print DTC and freeze frame data (FFD). GO TO 7.

NO >> GO TO 6.

#### 6. CHECK SYMPTOM

Perform trouble diagnosis for the applicable symptom. Refer to [WT-38, "Symptom Table"](#).

Is the cause of the malfunction detected?

YES >> GO TO 8.

NO >> GO TO 10.

#### 7. CIRCUIT DIAGNOSIS

Inspect the malfunctioning system indicated by the DTC code that is detected during self-diagnosis. Refer to [BCS-84, "DTC Index"](#).

>> GO TO 8.

A

B

C

D

WT

F

G

H

I

J

K

L

M

N

O

P

## DIAGNOSIS AND REPAIR WORK FLOW

< BASIC INSPECTION >

---

### 8. REPAIR WORK

---

Repair or replace the malfunctioning part.

>> GO TO 9.

### 9. PERFORM SELF-DIAGNOSIS

---

1. Select "SELF-DIAG RESULTS" in "AIR PRESSURE MONITOR" of "BCM".
2. Touch "ERASE" on CONSULT screen to erase memory.
3. Drive the vehicle.
4. Perform "SELF-DIAG RESULTS" in "AIR PRESSURE MONITOR" of "BCM".

Is any DTC detected?

- YES >> GO TO 7.  
NO >> GO TO 10.

### 10. FINAL CHECK

---

1. Perform a cruise test.
2. Check that the low tire pressure warning lamp turn OFF.

Does the tire pressure warning lamp turn OFF?

- YES >> INSPECTION END  
NO >> GO TO 2.

# ADDITIONAL SERVICE WHEN REPLACING BCM

< BASIC INSPECTION >

---

## ADDITIONAL SERVICE WHEN REPLACING BCM

### Description

INFOID:000000010993961

When replacing BCM, tire pressure sensor ID registration is required.

### Work Procedure

INFOID:000000010993962

#### 1. PERFORM TIRE PRESSURE SENSOR ID REGISTRATION

---

Perform tire pressure sensor ID registration.

>> Refer to [WT-23. "Work Procedure"](#).

A

B

C

D

WT

F

G

H

I

J

K

L

M

N

O

P

# TIRE PRESSURE SENSOR WAKE UP OPERATION

< BASIC INSPECTION >

## TIRE PRESSURE SENSOR WAKE UP OPERATION

### Description

INFOID:0000000110993963

This procedure must be done after replacement of a tire pressure sensor, BCM, or rotation of wheels.

### Work Procedure

INFOID:0000000110993964

#### 1. TIRE PRESSURE SENSOR WAKE-UP PROCEDURE

1. Turn the ignition switch ON.

**CAUTION:**

**Never start the engine.**

**NOTE:**

The position of an inactive tire pressure sensor can be identified by checking the blinking timing of the low tire pressure warning lamp.

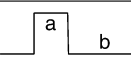
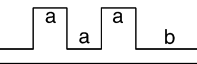
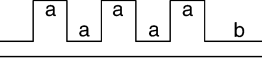
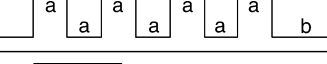
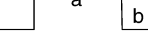
Low tire pressure warning lamp blinking timing		Activation tire position
ON OFF		Front LH
ON OFF		Front RH
ON OFF		Rear RH
ON OFF		Rear LH
ON OFF		All tires

JPEIC0089GB

2. Contact the tire pressure sensor activation tool (J-50190 or J-45295-A) (1) to the side of the tire at the location to the tire pressure sensor.
3. Press and hold the tire pressure sensor activation tool button while pushing the tool to the tire surface. (approximately for 5 seconds)

**CAUTION:**

**Perform the wake-up procedure starting from the vehicle front left wheel, then repeat the procedure in the order of the front right wheel, rear right wheel, and rear left wheel.**

4. Check that the turn signal lamps blink twice when the tire pressure sensor wake-up procedure for all wheels is completed.
5. Check that the low tire pressure warning lamp turns OFF, after the tire pressure sensor wake-up procedure is completed for all wheels and turns OFF.

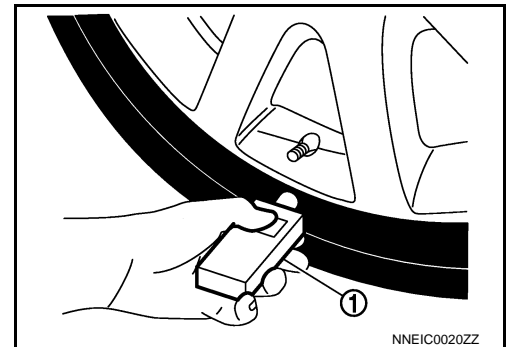

NNEIC0020ZZ

Is the tire pressure sensor wake-up procedure completed?

- YES >> Perform the tire pressure sensor ID registration procedure. Refer to [WT-23. "Work Procedure"](#).  
 NO >> Perform trouble diagnosis for the tire pressure sensor. Refer to [WT-27. "Diagnosis Procedure"](#).

# ID REGISTRATION

< BASIC INSPECTION >

## ID REGISTRATION

### Description

INFOID:000000010993965

This procedure must be done after replacing or rotating wheels, replacing tire pressure sensor or BCM.

### Work Procedure

INFOID:000000010993966

#### 1. TIRE PRESSURE SENSOR ID REGISTRATION PROCEDURE

##### CAUTION:

- To perform ID registration, observe the following points:
- Never register ID in a place where radio waves are interfered (e.g. radio tower).
- Never register ID in a place close to vehicles including TPMS.

☞ With CONSULT.

1. Display the "WORK SUPPORT" screen and select "ID REGIST".

Is the tire pressure sensor activation tool (J-50190 or J-45295-A) used for the tire pressure sensor ID registration procedure?

- YES >> GO TO 2.  
NO >> GO TO 3.

#### 2. TIRE PRESSURE SENSOR ID REGISTRATION PROCEDURE (WITH TIRE PRESSURE SENSOR ACTIVATION TOOL)

1. Turn the ignition switch ON.
2. Select the start button on the "ID REGIST" screen.
3. Contact the tire pressure sensor activation tool (J-50190 or J-45295-A) (1) to the side of the tire at the location to the tire pressure sensor.
4. Press and hold the tire pressure sensor activation tool button while pushing the tool to the tire surface. (approximately for 5 seconds)

##### CAUTION:

Perform the ID registration procedure starting from the vehicle front left wheel, then repeat the procedure in the order of the front right wheel, rear right wheel, and rear left wheel.

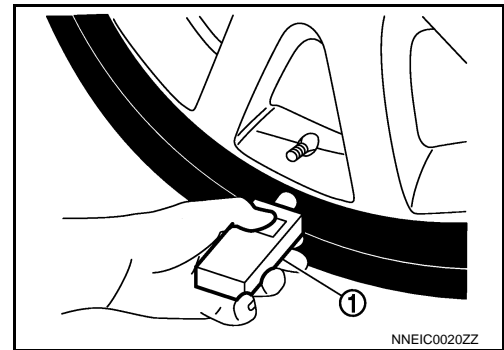

5. When ID registration is completed, check the following pattern at each wheel.

Sequence	ID registration position	Turn signal lamp	CONSULT
1	Front left wheel	2 blinks	"Red" ↓ "Green"
2	Front right wheel		
3	Rear right wheel		
4	Rear left wheel		

6. After the ID registration procedure for all wheels is completed, press "END" to end ID registration, and check that ID registration for all wheels is completed.

Is the check result normal?

- YES >> ID registration END.  
NO >> Refer to [WT-43. "Diagnosis Procedure"](#).

#### 3. TIRE PRESSURE SENSOR ID REGISTRATION PROCEDURE (WITHOUT TIRE PRESSURE SENSOR ACTIVATION TOOL)

1. Adjust the tire pressure for all wheels to match the list below.

## ID REGISTRATION

### < BASIC INSPECTION >

Tire position	Tire pressure kPa (kg/cm <sup>2</sup> , psi)
Front LH	240 (2.4, 35)
Front RH	220 (2.2, 31)
Rear RH	200 (2.0, 29)
Rear LH	180 (1.8, 26)

2. Drive the vehicle at a speed at more than 40 km/h (25 MPH) for 3 minutes or more, then perform the tire pressure sensor ID registration procedure.
3. After ID registration for all wheels is completed, press "END" to end ID registration.

ID registration position	CONSULT
Front LH	"Red" ↓ "Green"
Front RH	
Rear RH	
Rear LH	

4. Adjust the tire pressures for all wheels to the specified value. Refer to [WT-52. "Tire Air Pressure"](#).

Is ID registrations for all wheels completed?

YES >> ID registration END.

NO >> Performs trouble-diagnosis of the Tire Pressure Monitoring System (TPMS). Refer to [BCS-84. "DTC Index"](#).



# C1704, C1705, C1706, C1707 LOW TIRE PRESSURE

< DTC/CIRCUIT DIAGNOSIS >

## DTC/CIRCUIT DIAGNOSIS

### C1704, C1705, C1706, C1707 LOW TIRE PRESSURE

#### Description

INFOID:0000000010993967

When the tire pressure monitoring system detects low inflation pressure, the low tire pressure warning lamps in the combination meter comes on.

#### DTC Logic

INFOID:0000000010993968

#### DTC DETECTION LOGIC

DTC	Display item	Malfunction detected condition	Possible cause
C1704	LOW PRESSURE FL	Front LH tire pressure drops to * kPa (* kg/cm <sup>2</sup> , * psi) or less. [NOTE]	<ul style="list-style-type: none"> <li>Low tire pressure</li> <li>Tire pressure sensor malfunction</li> </ul>
C1705	LOW PRESSURE FR	Front RH tire pressure drops to * kPa (* kg/cm <sup>2</sup> , * psi) or less. [NOTE]	
C1706	LOW PRESSURE RR	Rear RH tire pressure drops to * kPa (* kg/cm <sup>2</sup> , * psi) or less. [NOTE]	
C1707	LOW PRESSURE RL	Rear LH tire pressure drops to * kPa (* kg/cm <sup>2</sup> , * psi) or less. [NOTE]	

\*: 182.7 kPa (1.9 kg/cm<sup>2</sup>, 26 psi): Standard air pressure is for 230 kPa (2.3 kg/cm<sup>2</sup>, 33 psi) vehicles.

#### DTC CONFIRMATION PROCEDURE

##### 1. DTC REPRODUCTION PROCEDURE

Ⓜ With CONSULT

- Turn the ignition switch ON.

**CAUTION:**

**Never start the engine.**

- Check the tire pressure for all wheels and adjust to the specified value. Refer to [WT-52, "Tire Air Pressure"](#).
- Perform "SELF-DIAG RESULTS" in "AIR PRESSURE MONITOR" of "BCM".

Is DTC "C1704", "C1705", "C1706", "C1707" detected?

- YES >> Perform trouble diagnosis. Refer to [WT-25, "Diagnosis Procedure"](#).  
 NO >> INSPECTION END

#### Diagnosis Procedure

INFOID:0000000010993969

##### 1. CHECK TIRE PRESSURE

Check the internal pressure of all wheels. Refer to [WT-52, "Tire Air Pressure"](#).

Is the inspection result normal?

- YES >> Replace the DTC-detected malfunctioning tire pressure sensor. Refer to [WT-49, "Exploded View"](#).  
 NO >> After adjusting the air pressure, GO TO 2.

##### 2. CHECK TIRE PRESSURE SIGNAL

Ⓜ With CONSULT

- Drive for 3 minutes at a speed of 40 km/h (25 MPH) or more, then drive normally for 10 minutes.
- Perform "DATA MONITOR" in "AIR PRESSURE MONITOR" of "BCM".
- Select "BCM" in "DATA MONITOR", and check that the tire pressures match the standard value.

Monitor item	Condition	Displayed value
AIR PRESS FL	Drive for 3 minutes at a speed of 40 km/h (25 MPH) or more, then drive normally for 10 minutes.	Internal pressure of tires
AIR PRESS FR		
AIR PRESS RR		
AIR PRESS RL		

**CAUTION:**

## **C1704, C1705, C1706, C1707 LOW TIRE PRESSURE**

< DTC/CIRCUIT DIAGNOSIS >

---

**Stop the vehicle and within 5 minutes, use “DATA MONITOR” in “AIR PRESSURE MONITOR” of “BCM” to display the tire pressure for all wheels.**

Is the inspection result normal?

- YES >> Inspect or repair the tires or wheels and adjust the tire pressure to the specification.
- NO >> GO TO 1.

# C1708, C1709, C1710, C1711 TIRE PRESSURE SENSOR

< DTC/CIRCUIT DIAGNOSIS >

## C1708, C1709, C1710, C1711 TIRE PRESSURE SENSOR

### DTC Logic

INFOID:000000010993970

### DTC DETECTION LOGIC

DTC	Display item	Malfunction detected condition	Possible cause
C1708	[NO DATA] FL	Tire pressure data signal from the front left wheel tire pressure sensor cannot be detected.	<ul style="list-style-type: none"> <li>• Harness or connector (Tire pressure receiver, BCM)</li> <li>• ID registration is not finished</li> <li>• Tire pressure sensor malfunction</li> <li>• BCM malfunction</li> </ul>
C1709	[NO DATA] FR	Tire pressure data signal from the front right wheel tire pressure sensor cannot be detected.	
C1710	[NO DATA] RR	Tire pressure data signal from the rear right wheel tire pressure sensor cannot be detected.	
C1711	[NO DATA] RL	Tire pressure data signal from the rear left wheel tire pressure sensor cannot be detected.	

### DTC CONFIRMATION PROCEDURE

#### 1. DTC REPRODUCTION PROCEDURE

Ⓜ With CONSULT

1. Drive for 3 minutes at a speed of 40 km/h (25 MPH) or more, then drive normally for 10 minutes.
2. Perform "SELF-DIAG RESULTS" in "AIR PRESSURE MONITOR" of "BCM".

Is DTC "C1708", "C1709", "C1710", "C1711" detected?

- YES >> Perform trouble diagnosis. Refer to [WT-27, "Diagnosis Procedure"](#).  
 NO >> INSPECTION END

### Diagnosis Procedure

INFOID:000000010993971

#### 1. CHECK TIRE PRESSURE SIGNAL

Ⓜ With CONSULT

1. Drive for 3 minutes at a speed of 40 km/h (25 MPH) or more, then drive normally for 10 minutes.
2. Perform "DATA MONITOR" in "AIR PRESSURE MONITOR" of "BCM".
3. Select "BCM" in "DATA MONITOR", and check that the tire pressures match the standard value.

Monitor item	Condition	Displayed value
AIR PRESS FL	Drive for 3 minutes at a speed of 40 km/h (25 MPH) or more, then drive normally for 10 minutes.	Internal pressure of tires
AIR PRESS FR		
AIR PRESS RR		
AIR PRESS RL		

#### CAUTION:

Stop the vehicle and within 5 minutes, use "DATA MONITOR" in "AIR PRESSURE MONITOR" of "BCM" to display the tire pressure for all wheels.

Is a tire pressure of 0 kPa (0 Psi) displayed for all wheels?

- YES >> GO TO 2.  
 NO >> GO TO 5.

#### 2. CHECK HARNESS BETWEEN BCM AND TIRE PRESSURE RECEIVER

1. Turn the ignition switch OFF.
2. Disconnect BCM harness connector and tire pressure receiver harness connector.
3. Check the continuity between BCM harness connector and tire pressure receiver harness connector.

# C1708, C1709, C1710, C1711 TIRE PRESSURE SENSOR

## < DTC/CIRCUIT DIAGNOSIS >

BCM		Tire pressure receiver		Continuity
Connector	Terminal	Connector	Terminal	
M123	137	M101	1	Existed
	138		4	
	139		2	

4. Check the continuity between BCM harness connector and ground.

BCM		—	Continuity
Connector	Terminal		
M123	137	Ground	Not existed
	138		
	139		

Is the inspection result normal?

YES >> GO TO 3.

NO >> Repair or replace damaged parts.

### 3. CHECK TIRE PRESSURE RECEIVER POWER SUPPLY CIRCUIT

1. Connect the BCM harness connector.

2. Turn the ignition switch ON.

**CAUTION:**

**Never start the engine.**

3. Check the voltage between the BCM harness connector and ground.

BCM		—	Voltage (Approx.)
Connector	Terminal		
M123	138	Ground	5 V

Is the inspection result normal?

YES >> GO TO 4.

NO >> Repair or replace damaged parts.

### 4. CHECK TIRE PRESSURE RECEIVER

Check tire pressure receiver. Refer to [WT-34, "Diagnosis Procedure"](#).

Is the inspection result normal?

YES >> GO TO 5.

NO >> Replace tire pressure receiver. Refer to [WT-51, "Exploded View"](#).

### 5. CHECK ID REGISTRATION

Perform ID registration of all tire pressure sensors. Refer to [WT-23, "Work Procedure"](#).

Can ID registration of all tire pressure sensors be completed?

YES >> GO TO 6.

NO >> Replace tire pressure sensor. Refer to [WT-49, "Exploded View"](#).

### 6. CHECK TIRE PRESSURE MONITORING SYSTEM

 With CONSULT

1. Drive at a speed of 40 km/h (25 MPH) or more for several minutes without stopping.

2. Perform "DATA MONITOR" in "AIR PRESSURE MONITOR" of "BCM".

3. Select "BCM" in "DATA MONITOR", and check that the tire pressures match the standard value.

# C1708, C1709, C1710, C1711 TIRE PRESSURE SENSOR

## < DTC/CIRCUIT DIAGNOSIS >

Monitor item	Condition	Displayed value
AIR PRESS FL	Drive at a speed of 40 km/h (25 MPH) or more, for several minutes without stopping.	Internal pressure of tires
AIR PRESS FR		
AIR PRESS RR		
AIR PRESS RL		

**CAUTION:**

Stop the vehicle and within 15 minutes, use “DATA MONITOR” in “AIR PRESSURE MONITOR” of “BCM” to read the tire pressure for all wheels.

Is the inspection result normal?

- YES >> Replace the DTC-detected malfunctioning tire pressure sensor. Refer to [WT-49, "Exploded View"](#).
- NO >> Replace BCM. Refer to [BCS-90, "Exploded View"](#).

A  
B  
C  
D  
E  
F  
G  
H  
I  
J  
K  
L  
M  
N  
O  
P

WT

# C1716, C1717, C1718, C1719 TIRE PRESSURE SENSOR

< DTC/CIRCUIT DIAGNOSIS >

## C1716, C1717, C1718, C1719 TIRE PRESSURE SENSOR

### DTC Logic

INFOID:000000010993972

#### DTC DETECTION LOGIC

DTC	Display item	Malfunction detected condition	Possible case
C1716	[PRESSDATA ERR] FL	Malfunction in the tire pressure data from the front left wheel tire pressure sensor.	<ul style="list-style-type: none"><li>• ID registration is not finished</li><li>• Tire pressure sensor malfunction</li></ul>
C1717	[PRESSDATA ERR] FR	Malfunction in the tire pressure data from the front right wheel tire pressure sensor.	
C1718	[PRESSDATA ERR] RR	Malfunction in the tire pressure data from the rear right wheel tire pressure sensor.	
C1719	[PRESSDATA ERR] RL	Malfunction in the tire pressure data from the rear left wheel tire pressure sensor.	

#### DTC CONFIRMATION PROCEDURE

##### 1. DTC REPRODUCTION PROCEDURE

Ⓟ With CONSULT

1. Turn the ignition switch ON.

**CAUTION:**

**Never start the engine.**

2. Check the tire pressure for all wheels and adjust to the specified value. Refer to [WT-52, "Tire Air Pressure"](#).
3. Perform "SELF-DIAG RESULTS" in "AIR PRESSURE MONITOR" of "BCM".

Is DTC "C1716", "C1717", "C1718", "C1719" detected?

- YES >> Perform trouble diagnosis. Refer to [WT-30, "Diagnosis Procedure"](#).  
NO >> INSPECTION END

#### Diagnosis Procedure

INFOID:000000010993973

##### 1. CHECK TIRE PRESSURE

Check the internal pressure of all wheels. Refer to [WT-52, "Tire Air Pressure"](#).

Is the inspection result normal?

- YES >> Replace the DTC-detected malfunctioning tire pressure sensor. Refer to [WT-49, "Exploded View"](#).  
NO >> After adjusting the tire pressure, GO TO 2.

##### 2. CHECK TIRE PRESSURE SIGNAL

Ⓟ With CONSULT

1. Check and adjust the tire pressure for all wheels. Refer to [WT-52, "Tire Air Pressure"](#).
2. Perform tire pressure sensor ID registration for all wheels. Refer to [WT-23, "Work Procedure"](#).
3. Drive for 3 minutes at a speed of 40 km/h (25 MPH) or more, then drive normally for 10 minutes.
4. Perform "DATA MONITOR" in "AIR PRESSURE MONITOR" of "BCM".
5. Select "BCM" in "DATA MONITOR", and check that the tire pressures match the standard value.

**CAUTION:**

**Stop the vehicle and within 15 minutes, use CONSULT "DATA MONITOR" to display the tire pressure for all wheels.**

6. Check that "DATA MONITOR" displays tire pressure of 438.60 kPa (4.47 kg/cm<sup>2</sup>, 63.60 Psi).

Is the inspection 438.60 kPa (4.47 kg/cm<sup>2</sup>, 63.60 Psi)?

- YES >> Replace tire pressure sensor the tire pressure 438.60 kPa (4.47 kg/cm<sup>2</sup>, 63.60 Psi) displayed.  
Refer to [WT-49, "Exploded View"](#).  
NO >> GO TO 1.

# C1729 VEHICLE SPEED SIGNAL

< DTC/CIRCUIT DIAGNOSIS >

## C1729 VEHICLE SPEED SIGNAL

### Description

INFOID:0000000010993974

BCM detects no vehicle speed signal.

### DTC Logic

INFOID:0000000010993975

### DTC DETECTION LOGIC

DTC number	Trouble diagnosis name	DTC detecting condition	Possible case
C1729	VHCL SPEED SIG ERR	Vehicle speed signal not detected.	<ul style="list-style-type: none"><li>CAN communication error</li><li>Unified meter and A/C amp. malfunction</li></ul>

### DTC CONFIRMATION PROCEDURE

#### 1. DTC REPRODUCTION PROCEDURE

④ With CONSULT

- Drive for several minutes at a speed of 40 km/h (25 MPH) or more, then stop the vehicle.
- Perform "SELF-DIAG RESULTS" in "AIR PRESSURE MONITOR" of "BCM".

Is DTC "C1729" detected?

- YES >> Perform trouble diagnosis. Refer to [WT-31, "Diagnosis Procedure"](#).  
NO >> INSPECTION END

### Diagnosis Procedure

INFOID:0000000010993976

#### 1. PERFORM UNIFIED METER AND A/C AMP. SELF-DIAGNOSIS

④ With CONSULT

Perform "SELF-DIAG RESULTS" of "METER/M&A".

Is any DTC detected?

- YES >> Check the DTC. Refer to [MWI-103, "DTC Index"](#).  
NO >> GO TO 2.

#### 2. CHECK INFORMATION

④ With CONSULT

- Perform "DATA MONITOR" in "AIR PRESSURE MONITOR" of "BCM".
- Select "BCM" in "DATA MONITOR", and check the input/output values. Refer to [BCS-45, "Reference Value"](#).

Is the inspection result normal?

- YES >> Check pin terminal and connection of each harness connector for malfunctioning conditions.  
NO >> Replace BCM. Refer to [BCS-90, "Exploded View"](#).

# C1734 BCM

< DTC/CIRCUIT DIAGNOSIS >

## C1734 BCM

### DTC Logic

INFOID:000000010993977

### DTC DETECTION LOGIC

DTC	Display item	Malfunction detected condition	Possible case
C1734	CONTROL UNIT	Tire pressure monitoring system malfunction in BCM	BCM malfunction

### DTC CONFIRMATION PROCEDURE

#### 1. DTC REPRODUCTION PROCEDURE

Ⓜ With CONSULT

1. Drive at a speed of 40 km/h (25 MPH) or more for several minutes without stopping.
2. Perform "SELF-DIAG RESULTS" in "AIR PRESSURE MONITOR" of "BCM".

**CAUTION:**

**Perform within 15 minutes after stop the vehicle.**

Is DTC "C1734" detected?

- YES >> Perform trouble diagnosis. Refer to [WT-32, "Diagnosis Procedure"](#).  
 NO >> INSPECTION END

### Diagnosis Procedure

INFOID:000000010993978

#### 1. CHECK BCM POWER SUPPLY

1. Turn the ignition switch OFF.
2. Disconnect BCM harness connector.
3. Check voltage between BCM harness connector terminals and ground.

BCM		—	Voltage
Connector	Terminal		
M118	1	Ground	Battery voltage
M119	11		

Is the power supply normal?

- YES >> GO TO 2.  
 NO >> Check the following. If any items are damaged, repair or replace damage parts.
- 40A fusible link [No. K located in the fuse block]. Refer to [PG-85, "Fuse and Fusible Link Arrangement"](#).
  - 10A fuse [No. 10 located in the fuse block (J/B)]. Refer to [PG-84, "Fuse, Connector and Terminal Arrangement"](#).
  - Harness for short or open between battery and BCM harness connector M118 terminal 1.
  - Harness for short or open between battery and BCM harness connector M119 terminal 11.
  - Check the Battery voltage.

#### 2. CHECK BCM GROUND

Check the continuity between BCM harness connector and ground.

BCM		—	Continuity
Connector	Terminal		
M119	13	Ground	Existed

Is the inspection result normal?

- YES >> GO TO 3.  
 NO >> Repair or replace damaged parts.

#### 3. CHECK HARNESS BETWEEN BCM AND TIRE PRESSURE RECEIVER

1. Disconnect tire pressure receiver harness connector.
2. Check the continuity between BCM harness connector and tire pressure receiver harness connector.



# C1734 BCM

## < DTC/CIRCUIT DIAGNOSIS >

BCM		Tire pressure receiver		Continuity
Connector	Terminal	Connector	Terminal	
M123	137	M101	1	Existed
	138		4	
	139		2	

3. Check the continuity between BCM harness connector and ground.

BCM		—	Continuity
Connector	Terminal		
M123	137	Ground	Not existed
	138		
	139		

Is the inspection result normal?

YES >> GO TO 4.

NO >> Repair or replace damaged parts.

### 4.CHECK BCM

Check the BCM input/output signal. Refer to [BCS-45, "Reference Value"](#).

Is the inspection result normal?

YES >> INSPECTION END

NO >> GO TO 5.

### 5.CHECK BCM HARNESS CONNECTOR

Check the BCM pin terminals for damage or loose connection with harness connector.

Is the inspection result normal?

YES >> Replace BCM. Refer to [BCS-90, "Exploded View"](#).

NO >> Check for looseness or damage at the harness connector pins of the BCM. Repair or replace if necessary.

# TIRE PRESSURE RECEIVER

< DTC/CIRCUIT DIAGNOSIS >

## TIRE PRESSURE RECEIVER

### Component Function Check

INFOID:000000010993979

#### 1. TIRE PRESSURE MONITORING SYSTEM OPERATION

④ With CONSULT

1. Drive for 3 minutes at a speed of 40 km/h (25 MPH) or more, then drive normally for 10 minutes.
2. On "DATA MONITOR", select "AIR PRESS FL", "AIR PRESS FR", "AIR PRESS RR" and "AIR PRESS RL", and check that the tire pressures match the standard value.

Monitor item	Condition	Displayed value
AIR PRESS FL	Drive for 3 minutes at a speed of 40 km/h (25 MPH) or more, then drive normally for 10 minutes.	Internal pressure of tires
AIR PRESS FR		
AIR PRESS RR		
AIR PRESS RL		

#### CAUTION:

Stop the vehicle and within 5 minutes, use CONSULT "DATA MONITOR" to display the tire pressure for all wheels.

Is the inspection result normal?

YES >> INSPECTION END

NO >> Perform trouble diagnosis. Refer to [WT-34, "Diagnosis Procedure"](#).

### Diagnosis Procedure

INFOID:000000010993980

#### 1. CHECK TIRE PRESSURE RECEIVER SIGNAL

1. Turn the ignition switch ON.

#### CAUTION:

Never start the engine.

2. Check tire pressure receiver connector and ground signal with oscilloscope.

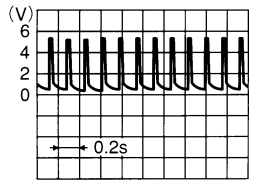
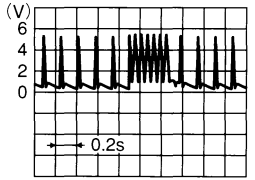
Tire pressure receiver		—	Condition	Voltage (Approx.)
Connector	Terminal			
M101	2	Ground	Stand by state	 <p>OCC3881D</p>
			When receiving the signal from the tire pressure sensor	 <p>OCC3880D</p>

Is the inspection result normal?

YES >> INSPECTION END

NO >> GO TO 2.

#### 2. CHECK TIRE PRESSURE RECEIVER INPUT VOLTAGE

1. Disconnect tire pressure receiver connector.
2. Check voltage between tire pressure receiver connector and ground.

# TIRE PRESSURE RECEIVER

## < DTC/CIRCUIT DIAGNOSIS >

Tire pressure receiver		—	Voltage (Approx.)
Connector	Terminal		
M101	4	Ground	5.0 V

Is the inspection result normal?

YES >> GO TO 3.

NO >> Repair or replace damaged parts.

### 3. CHECK TIRE PRESSURE RECEIVER GROUND CIRCUIT

1. Disconnect BCM harness connector.
2. Check continuity between BCM harness connector and tire pressure receiver connector.

BCM		Tire pressure receiver		Continuity
Connector	Terminal	Connector	Terminal	
M123	137	M101	1	Existed

3. Check continuity between BCM harness connector and ground.

BCM		—	Continuity
Connector	Terminal		
M123	137	Ground	Not existed

Is the inspection result normal?

YES >> GO TO 4.

NO >> Repair or replace damaged parts.

### 4. CHECK BCM CIRCUIT

Inspect the BCM circuit. Refer to [WT-32, "Diagnosis Procedure"](#).

Is the BCM circuit normal?

YES >> Replace tire pressure receiver. Refer to [WT-51, "Exploded View"](#).

NO >> Replace BCM. Refer to [BCS-90, "Exploded View"](#).

# LOW TIRE PRESSURE WARNING LAMP

< DTC/CIRCUIT DIAGNOSIS >

---

## LOW TIRE PRESSURE WARNING LAMP

### Component Function Check

INFOID:000000010993981

#### 1. CHECK THE ILLUMINATION OF THE LOW TIRE PRESSURE WARNING LAMP

Check that the low tire pressure warning lamp is turned OFF after illuminating for approximately 1 second, when the ignition switch is turned ON.

Is the inspection result normal?

YES >> INSPECTION END

NO >> Perform trouble diagnosis. Refer to [WT-36, "Diagnosis Procedure"](#).

### Diagnosis Procedure

INFOID:000000010993982

#### 1. POWER SUPPLY AND GROUND CIRCUIT

Check power supply and ground circuit. Refer to [WT-37, "Diagnosis Procedure"](#).

Is the inspection result normal?

YES >> GO TO 2.

NO >> Repair or replace damaged parts.

#### 2. PERFORM SELF-DIAGNOSIS

Ⓜ With CONSULT

Perform "SELF-DIAG RESULTS" in "AIR PRESSURE MONITOR" of "BCM".

Is any DTC detected?

YES >> Check the DTC. Refer to [BCS-84, "DTC Index"](#).

NO >> GO TO 3.

#### 3. CHECK LOW TIRE PRESSURE WARNING LAMP SIGNAL

Ⓜ With CONSULT

1. Turn the ignition switch ON.

**CAUTION:**

**Never start the engine.**

2. Perform "DATA MONITOR" in "AIR PRESSURE MONITOR" of "BCM".

3. Select "BCM" in "DATA MONITOR", and check that the low tire pressure warning lamp is turned OFF after illuminating for approximately 1 second, when the ignition switch is turned ON.

Is the inspection result normal?

YES >> Check the combination meter. Refer to [MWI-6, "METER SYSTEM : System Description"](#).

NO >> Replace the BCM. Refer to [BCS-90, "Exploded View"](#).

# POWER SUPPLY AND GROUND CIRCUIT

< DTC/CIRCUIT DIAGNOSIS >

## POWER SUPPLY AND GROUND CIRCUIT

### Diagnosis Procedure

INFOID:000000010993983

#### 1. POWER SUPPLY SYSTEM CHECK

1. Turn the ignition switch OFF.
2. Disconnect the BCM harness connector.
3. Turn the ignition switch ON.  
**CAUTION:**  
**Never start the engine.**
4. Check the voltage between the BCM harness connector and the ground.

BCM		—	Voltage
Connector	Terminal		
M118	1	Ground	Battery voltage
M119	11		

Is the inspection result normal?

- YES >> GO TO 2.  
NO >> Repair or replace damaged parts.

#### 2. GROUND SYSTEM INSPECTION

1. Turn the ignition switch OFF.
2. Check the continuity between the BCM harness connector and the ground.

BCM		—	Continuity
Connector	Terminal		
M119	13	Ground	Existed

Is the inspection result normal?

- YES >> • Check the 10A fuse [No. 10 in fuse block (J/B)].  
• Check the 40A fusible link [No. K in fuse block].  
NO >> Repair or replace damaged parts.

A  
B  
C  
D  
F  
G  
H  
I  
J  
K  
L  
M  
N  
O  
P

WT













# SYMPTOM DIAGNOSIS

## TPMS

### Symptom Table



INFOID:000000010993984

#### LOW TIRE PRESSURE WARNING LAMP SYMPTOM CHART

Diagnosis items	Symptom (Ignition switch ON)	Low tire pressure warning lamp	Cause	Action
Low tire pressure warning lamp	The low tire pressure warning lamp illuminates for 1 second, then turns OFF.	 ON 1 sec > stays OFF SEIA0592E	Wake-up operation for all tire pressure sensors at wheels is completed.	No system malfunctions
	The low tire pressure warning lamp repeats blinking ON for 2 seconds and OFF for 0.2 seconds.	 Blinks:  ON 2 sec > OFF 0.2 sec SEIA0593E	Wake-up operation for all tire pressure sensors at wheels is not completed.	Perform the wake-up operation for all tire pressure sensors at wheels. Refer to <a href="#">WT-22, "Work Procedure"</a> .
	The low tire pressure warning lamp blinks once.	 Blinks 1 time ON 0.3 sec > OFF 1.0 sec JPEIC0090GB	The front left tire pressure sensor is not activated.	Perform the wake-up operation for the tire pressure sensor at front left wheel. Refer to <a href="#">WT-22, "Work Procedure"</a> .
	The low tire pressure warning lamp repeats blinking twice.	  Blinks 2 times ON 0.3 sec > OFF 0.3 sec SEIA0595E	The front right tire pressure sensor is not activated.	Perform the wake-up operation for the tire pressure sensor at front right wheel. Refer to <a href="#">WT-22, "Work Procedure"</a> .
	The low tire pressure warning lamp repeats blinking for 3 times.	   Blinks 3 times ON 0.3 sec > OFF 0.3 sec SEIA0596E	The rear right tire pressure sensor is not activated.	Perform the wake-up operation for the tire pressure sensor at rear right wheel. Refer to <a href="#">WT-22, "Work Procedure"</a> .
	The low tire pressure warning lamp repeats blinking for 4 times.	    Blinks 4 times ON 0.3 sec > OFF 0.3 sec SEIA0597E	The rear left tire pressure sensor is not activated.	Perform the wake-up operation for the tire pressure sensor at rear left wheel. Refer to <a href="#">WT-22, "Work Procedure"</a> .

# TPMS

## < SYMPTOM DIAGNOSIS >

Diagnosis items	Symptom (Ignition switch ON)	Low tire pressure warning lamp	Cause	Action
Low tire pressure warning lamp	The low tire pressure warning lamp turns ON and stays illuminated.	 Comes ON and stays ON <small>SEIA0598E</small>	Low tire pressure	Check the tire pressure for all wheels and adjust to the specified value. Refer to <a href="#">WT-52, "Tire Air Pressure"</a> .
	The low tire pressure warning lamp repeats blinking at 0.5-second intervals for 1 minute, and then stays illuminated.	 Blinks 1 min ON 0.5 sec > OFF 0.5 sec and stays ON <small>SEIA0788E</small>	The combination meter fuse is open or removed (or pulled out).	Check and install the combination meter fuse. If necessary, replace the fuse.
			The BCM harness connector is removed.	Check the connection conditions of the BCM harness connector, and repair if necessary.
Hazard warning lamp	The hazard warning lamp does not blink twice when the tire pressure sensor is activated.	—	Tire Pressure Monitoring System (TPMS) malfunction.	<ul style="list-style-type: none"> <li>Perform CONSULT self-diagnosis. Refer to <a href="#">WT-9, "COMMON ITEM : CONSULT Function (BCM - COMMON ITEM)"</a>.</li> <li>If necessary, perform tire pressure sensor ID registration. Refer to <a href="#">WT-23, "Work Procedure"</a>.</li> </ul>
			<ol style="list-style-type: none"> <li>The tire pressure sensor activation tool (J-50190 or J-45295-A) does not activate.</li> <li>The ignition switch is OFF when the tire pressure sensor wake-up operation is performed.</li> <li>The tire pressure sensor activation tool (J-50190 or J-45295-A) is not used in the correct position.</li> <li>The tire pressure sensor is already waked up.</li> </ol>	<ol style="list-style-type: none"> <li>Replace the battery in the tire pressure sensor activation tool (J-50190 or J-45295-A).</li> <li>Turn the ignition switch ON when performing the tire pressure sensor wake-up operation.</li> <li>Operate the tire pressure sensor activation tool (J-50190 or J-45295-A) in the correct position when performing the wake-up operation.</li> <li>No procedure.</li> </ol>

**NOTE:**

If tire pressure sensor wake-up operation is not completed for two or more tire pressure sensors, the applicable low tire pressure warning lamp blinking patterns are displayed continuously.  
 (Example: Blinks once/OFF/blinks 3 times = Wake-up operation is not completed at the front left wheel and rear right wheel tire pressure sensors.)

A  
B  
C  
D  
WT  
F  
G  
H  
I  
J  
K  
L  
M  
N  
O  
P

# LOW TIRE PRESSURE WARNING LAMP DOES NOT TURN ON

< SYMPTOM DIAGNOSIS >

---

## LOW TIRE PRESSURE WARNING LAMP DOES NOT TURN ON

### Description

INFOID:000000010993985

The low tire pressure warning lamp does not illuminate when the ignition switch is turned ON.

**NOTE:**

The low tire pressure warning lamp illuminates for approximately 1 second and then turns OFF when the ignition switch is turned ON. This is to check that no abnormal condition is present in the tire pressure monitoring system.

The lamp bulb may be burnt out or the tire pressure monitoring system may be malfunctioning if the low tire pressure warning lamp does not illuminate when the ignition switch is turned ON.

### Diagnosis Procedure

INFOID:000000010993986

#### 1. CHECK LOW TIRE PRESSURE WARNING LAMP

---

Perform trouble diagnosis of the low tire pressure warning lamp. Refer to [WT-36, "Diagnosis Procedure"](#).

Is the inspection result normal?

- YES >> Check pin terminal and connection of each connector for damage and loose connection.
- NO >> Repair or replace damaged parts.



# LOW TIRE PRESSURE WARNING LAMP DOES NOT TURN OFF

< SYMPTOM DIAGNOSIS >

## LOW TIRE PRESSURE WARNING LAMP DOES NOT TURN OFF

### Description

INFOID:000000010993987

The low tire pressure warning lamp does not turn OFF after several seconds is passed after engine starts.

### Diagnosis Procedure

INFOID:000000010993988

#### 1. CHECK TIRE PRESSURE

1. Turn the ignition switch ON.

**CAUTION:**

**Never start the engine.**

2. Check the tire pressure for all wheels and adjust to the specified value. Refer to [WT-52, "Tire Air Pressure"](#).

Is the inspection result normal?

YES >> GO TO 2.

NO >> Inspect or repair the tires or wheels.

#### 2. CHECK LOW TIRE PRESSURE WARNING LAMP

Check low tire pressure warning lamp display.

Does not low tire pressure warning lamp turn OFF?

YES >> GO TO 3.

NO >> INSPECTION END

#### 3. CHECK BCM

 With CONSULT

Perform "SELF-DIAG RESULTS" in "AIR PRESSURE MONITOR" of "BCM".

Is any DTC detected?

YES >> Check the DTC. Refer to [BCS-84, "DTC Index"](#).

NO >> GO TO 4.

#### 4. CHECK BCM POWER SUPPLY AND GROUND CIRCUIT

Perform the trouble diagnosis for power supply and ground circuit. Refer to [WT-37, "Diagnosis Procedure"](#).

Is the inspection result normal?

YES >> Replace BCM. Refer to [BCS-90, "Exploded View"](#).

NO >> Repair or replace error-detected parts.

A  
B  
C  
D  
WT  
F  
G  
H  
I  
J  
K  
L  
M  
N  
O  
P

# LOW TIRE PRESSURE WARNING LAMP BLINKS

< SYMPTOM DIAGNOSIS >

## LOW TIRE PRESSURE WARNING LAMP BLINKS

### Description

INFOID:000000010993989

The low tire pressure warning lamp blinks when the ignition switch is turned ON.

**NOTE:**

The position of an inactive tire pressure sensor can be identified by checking the blinking timing of the low tire pressure warning lamp.

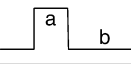
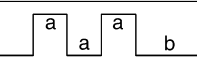
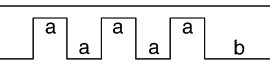
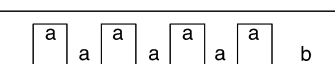
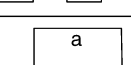
Low tire pressure warning lamp blinking timing		Activation tire position
ON 	a : 0.3 sec. b : 1.0 sec.	Front LH
ON 	a : 0.3 sec. b : 1.0 sec.	Front RH
ON 	a : 0.3 sec. b : 1.0 sec.	Rear RH
ON 	a : 0.3 sec. b : 1.0 sec.	Rear LH
ON 	a : 2 sec. b : 0.2 sec.	All tires

JPEIC0089GB

### Diagnosis Procedure

INFOID:000000010993990

#### 1. TIRE PRESSURE SENSOR WAKE-UP OPERATION

Perform the tire pressure sensor wake-up. Refer to [WT-22, "Work Procedure"](#).

Is the tire pressure sensor wake-up completed?

YES >> GO TO 2.

NO >> Perform trouble diagnosis for the tire pressure sensor. Refer to [WT-27, "Diagnosis Procedure"](#).

#### 2. TIRE PRESSURE SENSOR ID REGISTRATION

Perform tire pressure sensor ID registration. Refer to [WT-23, "Work Procedure"](#).

Is tire pressure sensor ID registration completed?

YES >> INSPECTION END

NO >> Perform the self-diagnosis for "AIR PRESSURE MONITOR". Refer to [BCS-84, "DTC Index"](#).

# ID REGISTRATION CANNOT BE COMPLETED

< SYMPTOM DIAGNOSIS >

## ID REGISTRATION CANNOT BE COMPLETED

### Description

INFOID:000000010993991

The ID of the tire pressure sensor installed in each wheel cannot be registered in the tire pressure monitoring system. Inspect the tire pressure sensor or the tire pressure monitoring system circuit.

### Diagnosis Procedure

INFOID:000000010993992

#### 1. TIRE PRESSURE SENSOR WAKE-UP

Perform the tire pressure sensor wake-up. Refer to [WT-22. "Work Procedure"](#).

Is the tire pressure sensor wake-up completed?

YES >> GO TO 3.

NO >> GO TO 2.

#### 2. CHECK TIRE PRESSURE SENSOR ACTIVATION TOOL

Check tire pressure sensor activation tool.

Is the inspection result normal?

YES >> GO TO 3.

NO >> Replace the battery of tire pressure sensor activation tool or repair/replace the tire pressure sensor activation tool.

#### 3. TIRE PRESSURE SENSOR ID REGISTRATION

Perform tire pressure sensor ID registration. Refer to [WT-23. "Work Procedure"](#).

##### **CAUTION:**

**To perform ID registration, observe the following points:**

- Never register ID in a place where radio waves are interfered (e.g. radio tower).
- Never register ID in a place close to vehicles including TPMS.

Is tire pressure sensor ID registration completed?

YES >> INSPECTION END

NO >> GO TO 4.

#### 4. CHECK TIRE PRESSURE SIGNAL

Change the work location and perform ID registration again.

##### **NOTE:**

Depending on the tire pressure sensor position\*, a blind spot exists, and the tire pressure receiver gets a poor reception. If an ID registration is performed under this condition, the registration may not be completed.

In such case, follow the instructions below to improve the radio wave receiving environment.

- Rotate tire by 90°, 180°, or 270°. (This Step is to change tire pressure sensor position.)
- Open the door close to the tire of which ID registration is ongoing.

\*: Radio wave reception condition depends on vehicle architecture (e.g. body harness layout, tire wheel design) or environment.

When ID registration is performed, which wheels do not react?

All wheels react and ID registration is possible.>>INSPECTION END

Only certain wheel(s) do not react.>>Replace applicable tire pressure sensor. Refer to [WT-49. "Removal and Installation"](#).

All wheels do not react.>>Check the tire pressure receiver. Refer to [WT-34. "Component Function Check"](#).

A  
B  
C  
D  
E  
F  
G  
H  
I  
J  
K  
L  
M  
N  
O  
P

WT

# NOISE, VIBRATION AND HARSHNESS (NVH) TROUBLESHOOTING

< SYMPTOM DIAGNOSIS >

## NOISE, VIBRATION AND HARSHNESS (NVH) TROUBLESHOOTING

### NVH Troubleshooting Chart

INFOID:000000010993993

Use chart below to find the cause of the symptom. If necessary, repair or replace these parts.

Symptom		Possible cause and SUSPECTED PARTS		Reference page			
				2WD models: <a href="#">FSU-10</a> , <a href="#">FSU-13</a>	AWD models: <a href="#">FSU-33</a> , <a href="#">FSU-37</a>		
TIRES	Noise	x	x	x	x	<a href="#">WT-47</a> , " <a href="#">Inspection</a> "	NVH in DLN section.
	Shake	x	x	x	x	<a href="#">WT-45</a> , " <a href="#">Adjustment</a> "	NVH in DLN section.
	Vibration			x		<a href="#">WT-52</a> , " <a href="#">Tire Air Pressure</a> "	NVH in FAX and FSU sections.
	Shimmy	x	x	x	x	<a href="#">WT-45</a> , " <a href="#">Adjustment</a> "	NVH in RAX and RSU sections.
	Judder	x	x	x	x	<a href="#">WT-45</a> , " <a href="#">Adjustment</a> "	Refer to TIRES in this chart.
	Poor quality ride or handling	x	x	x	x	—	Refer to ROAD WHEEL in this chart.
	Noise	x	x	x	x	—	NVH in FAX, RAX section.
	Shake	x	x	x	x	—	NVH in BR section.
	Shimmy, Judder	x	x	x	x	<a href="#">WT-52</a> , " <a href="#">Tire Air Pressure</a> "	NVH in ST section.
	Poor quality ride or handling	x	x	x	x	—	NVH in ST section.
ROAD WHEEL	Noise	x	x	x	x	Improper installation, looseness	
	Shake	x	x	x	x	Out-of-round	
	Shimmy, Judder	x	x	x	x	unbalance	
	Poor quality ride or handling	x	x	x	x	Incorrect tire pressure	
						Uneven tire wear	
						Deformation or damage	
						Non-uniformity	
						Incorrect tire size	
						PROPELLER SHAFT	
						DIFFERENTIAL	
						FRONT AXLE AND FRONT SUSPENSION	
						REAR AXLE AND REAR SUSPENSION	
						TIRES	
						ROAD WHEELS	
						DRIVE SHAFT	
						BRAKE	
						STEERING	

x: Applicable

# ROAD WHEEL

< PERIODIC MAINTENANCE >

## PERIODIC MAINTENANCE

### ROAD WHEEL

#### Adjustment

INFOID:0000000010993994

#### BALANCING WHEELS (BONDING WEIGHT TYPE)

##### Preparation Before Adjustment

Using releasing agent, remove double-faced adhesive tape from the road wheel.

##### **CAUTION:**

- **Be careful not scratch the road wheel during removal.**
- **After removing double-faced adhesive tape, wipe clean traces of releasing agent from the road wheel.**

##### Wheel Balance Adjustment

- If a tire balance machine has adhesion balance weight mode settings and drive-in weight mode setting, select and adjust a drive-in weight mode suitable for road wheels.

1. Set road wheel on tire balance machine using the center hole as a guide. Start the tire balance machine.
2. When inner and outer unbalance values are shown on the tire balance machine indicator, multiply outer unbalance value by 5/3 to determine balance weight that should be used. Select the outer balance weight with a value closest to the calculated value above and install in to the designated outer position of, or at the designated angle in relation to the road wheel.

##### **CAUTION:**

- **Never install the inner balance weight before installing the outer balance weight.**
- **Before installing the balance weight, be sure to clean the mating surface of the road wheel.**

- a. Indicated un balance value  $\times 5/3 =$  balance weight to be installed

##### **Calculation example:**

$23 \text{ g (0.81 oz)} \times 5/3 = 38.33 \text{ g (1.35 oz)} \Rightarrow 37.5 \text{ g (1.32 oz)}$  balance weight (closer to calculated balance weight value)

##### **NOTE:**

Note that balance weight value must be closer to the calculated balance weight value.

##### **Example:**

$36.2 \Rightarrow 35 \text{ g (1.23 oz)}$

$36.3 \Rightarrow 37.5 \text{ g (1.32 oz)}$

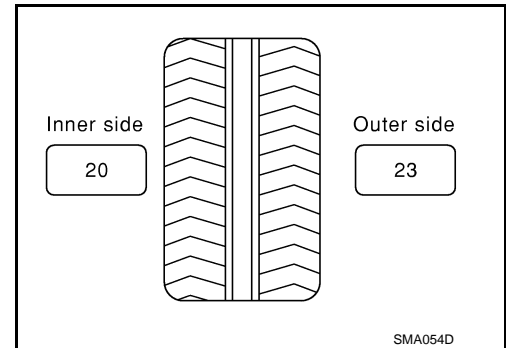

- b. Installed balance weight in the position.

A  
B  
C  
D  
WT  
F  
G  
H  
I  
J  
K  
L  
M  
N  
O  
P

# ROAD WHEEL

## < PERIODIC MAINTENANCE >

- When installing balance weight (1) to road wheels, set it into the grooved area (A) on the inner wall of the road wheel as shown in the figure so that the balance weight center (B) is aligned with the tire balance machine indication position (angle) (C).

### CAUTION:

- Always use genuine NISSAN adhesion balance weights.
- Balance weights are non-reusable; always replace with new ones.
- Never install more than three sheets of balance weight.

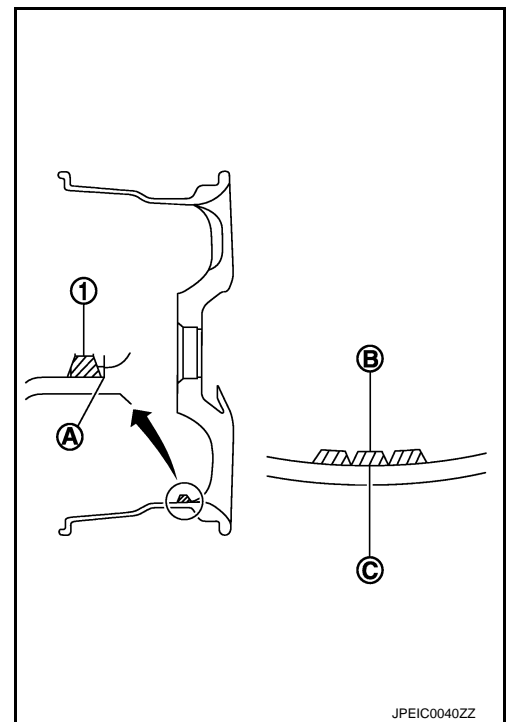

- c. If calculated balance weight value exceeds 50 g (1.76 oz), install two balance weight sheets in line with each other as shown in the figure.

### CAUTION:

**Never install one balance weight sheet on top another.**

- Start tire balance machine again.
- Install drive-in balance weight on inner side of road wheel in the tire balance machine indication position (angle).

### CAUTION:

**Never install more than two balance weight.**

- Start tire balance machine. Make sure that inner and outer residual unbalance values are 5 g (0.17 oz) each or below.
- If either residual unbalance value exceeds 5 g (0.17 oz), repeat installation procedures.

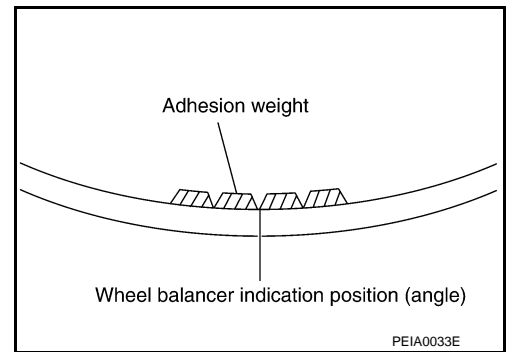

### Limit

**Dynamic (At flange) :** Refer to [WT-52, "Road Wheel"](#).

**Static (At flange) :** Refer to [WT-52, "Road Wheel"](#).

## TIRE ROTATION

- Follow the maintenance schedule for tire rotation service intervals. Refer to [MA-4, "Explanation of General Maintenance"](#).
- When installing the wheel, tighten wheel nuts to the specified torque. Refer to [WT-47, "Exploded View"](#).

### CAUTION:

- Never include the T-type spare tire when rotating the tires.
  - When installing wheels, tighten them diagonally by dividing the work two to three times in order to prevent the wheels from developing any distortion.
  - Be careful not to tighten wheel nut at torque exceeding the criteria for preventing strain of disc rotor.
  - Use NISSAN genuine wheel nuts for aluminum wheels.
- Perform the ID registration, after tire rotation. Refer to [WT-23, "Work Procedure"](#).

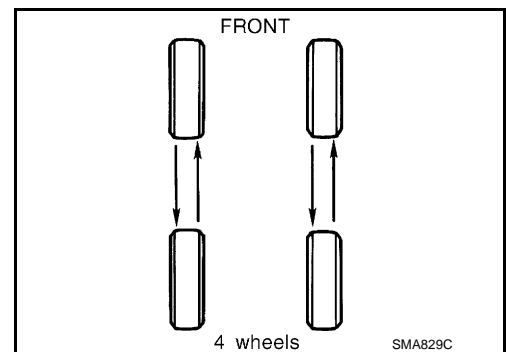

# ROAD WHEEL TIRE ASSEMBLY

< REMOVAL AND INSTALLATION >

## REMOVAL AND INSTALLATION

### ROAD WHEEL TIRE ASSEMBLY

Exploded View

INFOID:000000010993995

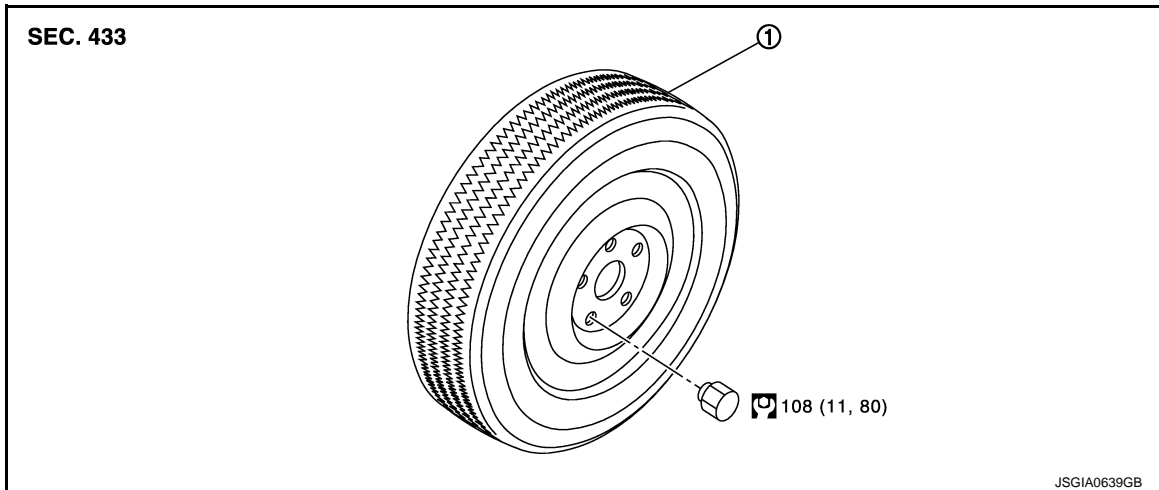

1. Tire assembly

Refer to [GI-4, "Components"](#) for symbols in the figure.

### Removal and Installation

INFOID:000000010993996

#### REMOVAL

1. Remove wheel nuts.
2. Remove tire assembly.

#### INSTALLATION

Note the following, install in the reverse order of removal.

- When replacing or rotating wheels, perform the ID registration. Refer to [WT-23, "Work Procedure"](#).

### Inspection

INFOID:000000010993997

#### ALUMINUM WHEEL

1. Check tires for wear and improper inflation.
2. Check wheels for deformation, cracks and other damage. If deformed, remove wheel and check wheel runout.
  - a. Remove tire from aluminum wheel and mount on a tire balance machine.
  - b. Set dial indicator as shown in the figure.
  - c. Check runout, If the axial runout (A) or radial runout (B) exceeds the limit, replace aluminum wheel.

#### Limit

**Axial runout (A)** : Refer to [WT-52, "Road Wheel"](#).

**Radial runout (B)** : Refer to [WT-52, "Road Wheel"](#).

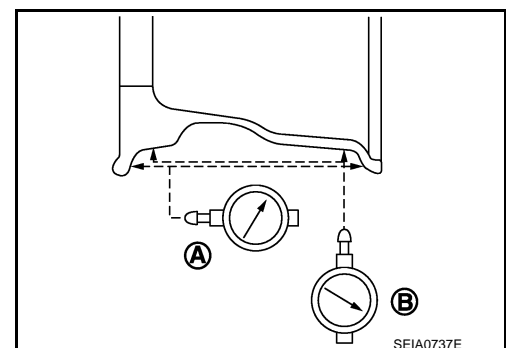

#### STEEL WHEEL

1. Check tires for wear and improper inflation.

## ROAD WHEEL TIRE ASSEMBLY

### < REMOVAL AND INSTALLATION >

2. Check wheels for deformation, clacks and other damage. If deformed, remove wheel and check wheel runout.
  - a. Remove tire from steel wheel and mount wheel on a tire balance machine.
  - b. Set two dial indicators as shown in the illustration.
  - c. Set each dial indicator to "0".
  - d. Rotate wheel and check dial indicators at several points around the circumference of the wheel.
  - e. Calculate runout at each point as shown below.

**Axial runout (A)** :  $(\textcircled{1} + \textcircled{2})/2$

**Radial runout (B)** :  $(\textcircled{3} + \textcircled{4})/2$

- f. Select maximum positive runout value and the maximum negative value. Add the two values to determine total runout.

**CAUTION:**

**In case a positive or negative value is not available, use the maximum value (negative or positive) for total runout.**

**Limit**

**A** : Refer to [WT-52, "Road Wheel"](#).

**B** : Refer to [WT-52, "Road Wheel"](#).

- g. If the total runout value exceeds limit, replace steel wheel.

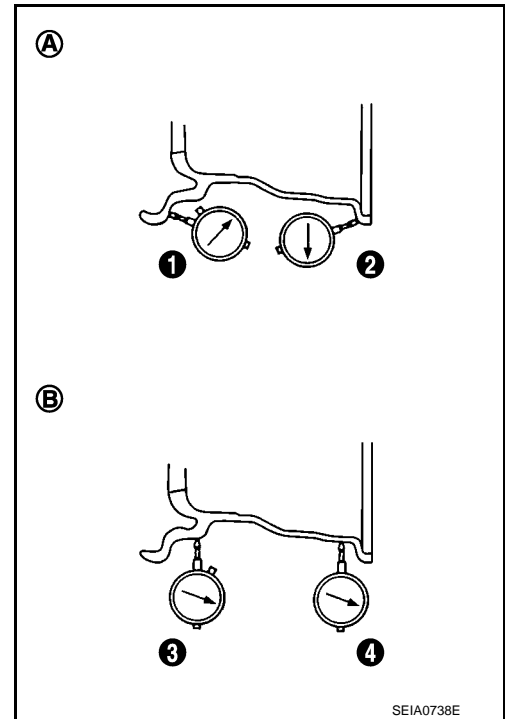



# TIRE PRESSURE SENSOR

< REMOVAL AND INSTALLATION >

## TIRE PRESSURE SENSOR

### Exploded View

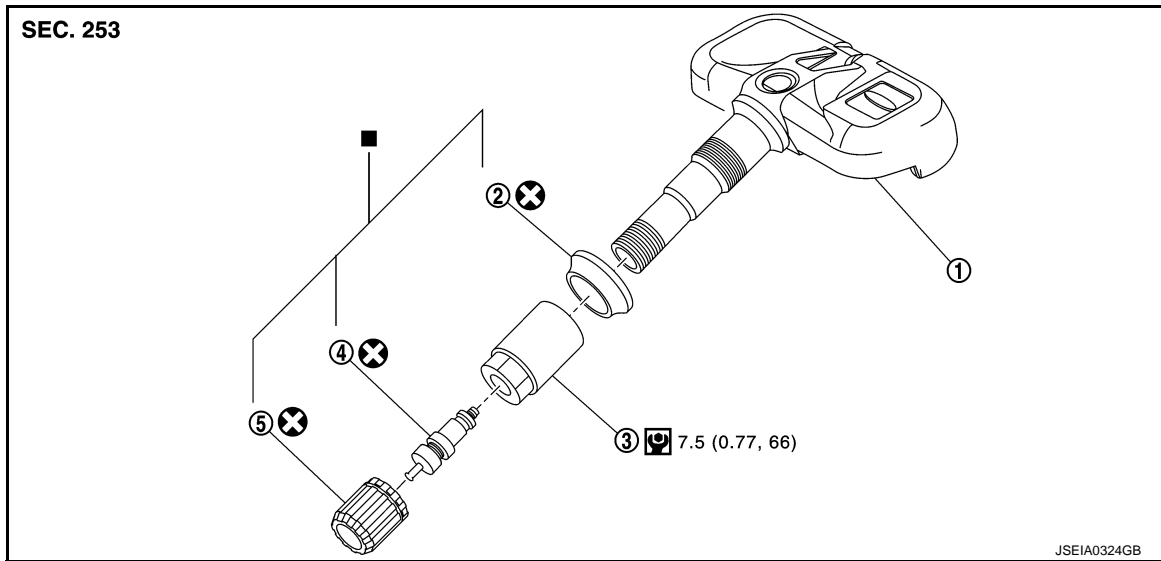

- |                         |                 |              |
|-------------------------|-----------------|--------------|
| 1. Tire pressure sensor | 2. Grommet seal | 3. Valve nut |
| 4. Valve core           | 5. Valve cap    |              |

■ : Parts that are replaced as a set when the tire is replaced.

Refer to [GI-4, "Components"](#) for symbols not described above.

### Removal and Installation

INFOID:000000010993999

#### REMOVAL

1. Remove tire assembly. Refer to [WT-47, "Removal and Installation"](#).
2. Remove valve cap, valve core and then deflate tire.

#### NOTE:

If the tire is reused, apply a matching mark to the position of the tire road wheel valve hole for the purpose of wheel balance adjustment after installation.

3. Remove valve nut retaining tire pressure sensor and allow tire pressure sensor to fall into tire.
4. Use the tire changer and disengage the tire beads.

#### CAUTION:

- Verify that the tire pressure sensor (1) is at the bottom of the tire while performing the above.
  - Be sure not to damage the road wheel or tire pressure sensor.
5. Apply bead cream or an equivalent to the tire beads.
  6. Set tire onto the tire changer turntable so that the tire pressure sensor inside the tire is located close to the road wheel valve hole.

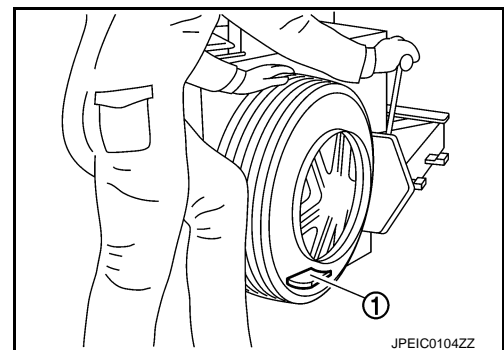

# TIRE PRESSURE SENSOR

## < REMOVAL AND INSTALLATION >

- Turn tire so that valve hole is at bottom and bounce so that tire pressure sensor (1) is near valve hole. Carefully lift tire onto turntable and position valve hole (and tire pressure sensor) 270 degree from mounting/dismounting head (2).

**CAUTION:**

**Be sure not to damage the road wheel and tire pressure sensor.**

- Remove tire pressure sensor from tire.
- Remove the grommet seal.

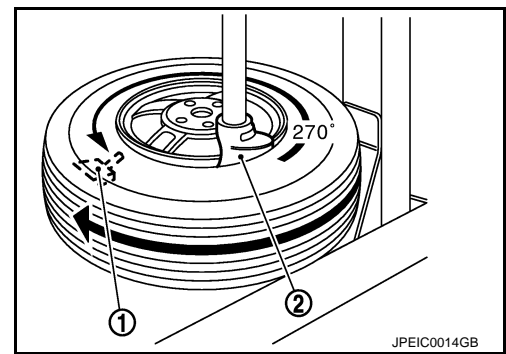

## INSTALLATION

- Apply bead cream or an equivalent to the tire beads.
- Install the tire inside beads (1) onto the road wheel (2) in the position shown in the figure.
- Install grommet seal to the tire pressure sensor.

**CAUTION:**

- Never reuse grommet seal.
- Insert grommet seal all the way to the base.

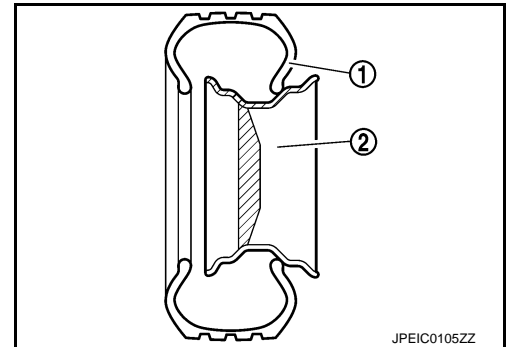

- Hold tire pressure sensor as shown in the figure, and press the sensor in the direction shown by arrow (←) to bring it into absolute contact with valve hole. After this, tighten valve nut to the specified torque.

**CAUTION:**

- Never reuse valve core and valve cap.
- Check that grommet seal is free of foreign matter.
- Check that grommet seal contacts horizontally with road wheel.
- Manually tighten valve nut all the way to the wheel. (Never use a power tool to avoid impact.)

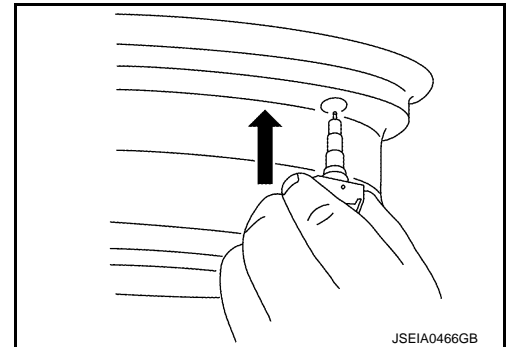

- Set the tire onto the turntable so that the tire changer arm (2) is at a position approximately 270° from the tire pressure sensor (1).

**CAUTION:**

**Be sure that the arm does not contact the tire pressure sensor.**

- Install the tire outer side beads onto the road wheel.

**CAUTION:**

**When installing, check that the tire does not turn together with the road wheel.**

- Check the tire pressure for all wheels and adjust to the specified value. Refer to [WT-52, "Tire Air Pressure"](#).

**NOTE:**

Before adding air, align the tire with the position of the matching mark applied at the time of removal.

- Install tire to the vehicle. Refer to [WT-47, "Removal and Installation"](#).
- Perform tire pressure sensor ID registration. Refer to [WT-23, "Work Procedure"](#).

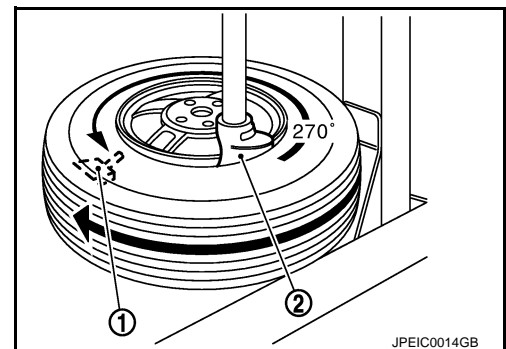

# TIRE PRESSURE RECEIVER

< REMOVAL AND INSTALLATION >

## TIRE PRESSURE RECEIVER

### Exploded View

INFOID:000000010994000

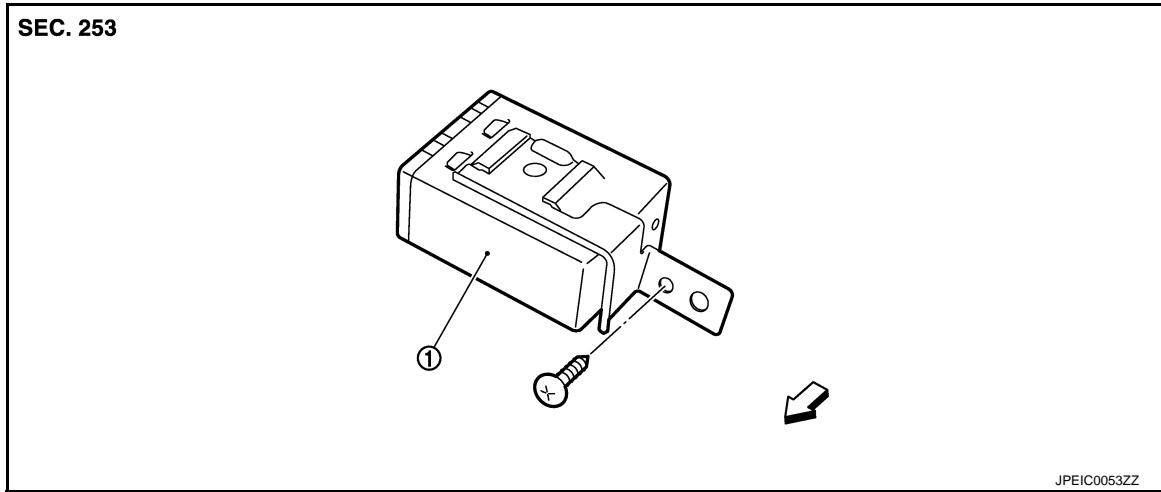

1. Tire pressure receiver

←: Vehicle front

### Removal and Installation

INFOID:000000010994001

#### REMOVAL

1. Remove the instrument lower cover. Refer to [IP-12. "Exploded View"](#).
2. Remove the glove box assembly.
3. Remove the instrument lower panel RH.
4. Disconnect tire pressure receiver harness connector.
5. Remove Tire pressure receiver mounting screw.
6. Remove tire pressure receiver.

#### INSTALLATION

Install is the reverse order of removal.

A  
B  
C  
D  
WT  
F  
G  
H  
I  
J  
K  
L  
M  
N  
O  
P

## SERVICE DATA AND SPECIFICATIONS (SDS)

< SERVICE DATA AND SPECIFICATIONS (SDS)

## SERVICE DATA AND SPECIFICATIONS (SDS)

### SERVICE DATA AND SPECIFICATIONS (SDS)

#### Road Wheel

INFOID:0000000010994002

#### ALUMINUM WHEEL (CONVENTIONAL)

Item		Limit
Runout	Axial runout	Less than 0.3 mm (0.012 in)
	Radial runout	
Allowable unbalance	Dynamic (At flange)	Less than 5 g (0.17 oz) (one side)
	Static (At flange)	Less than 10 g (0.35 oz)

#### STEEL WHEEL (FOR EMERGENCY USE)

Item		Limit
Runout	Axial runout (Average)	Less than 1.5 mm (0.059 in)
	Radial runout (Average)	

#### Tire Air Pressure

INFOID:0000000010994003

Unit: kPa (kg/cm<sup>2</sup>, psi)

Tire size	Air pressure	
	Front	Rear
P225/55R17 95V	230 (2.3, 33)	
T145/80D17 107M	420 (4.2, 60)	